

QL Today

Volume 1
Issue 2
July/August
1996

The Magazine about QL, QDOS,
Sinclair Computers, SMSQ...

- **The Sinclair Service List**
- **QL Writer's Pack Review**
- **Squash those PCs**
- **The Bedford QL Show**

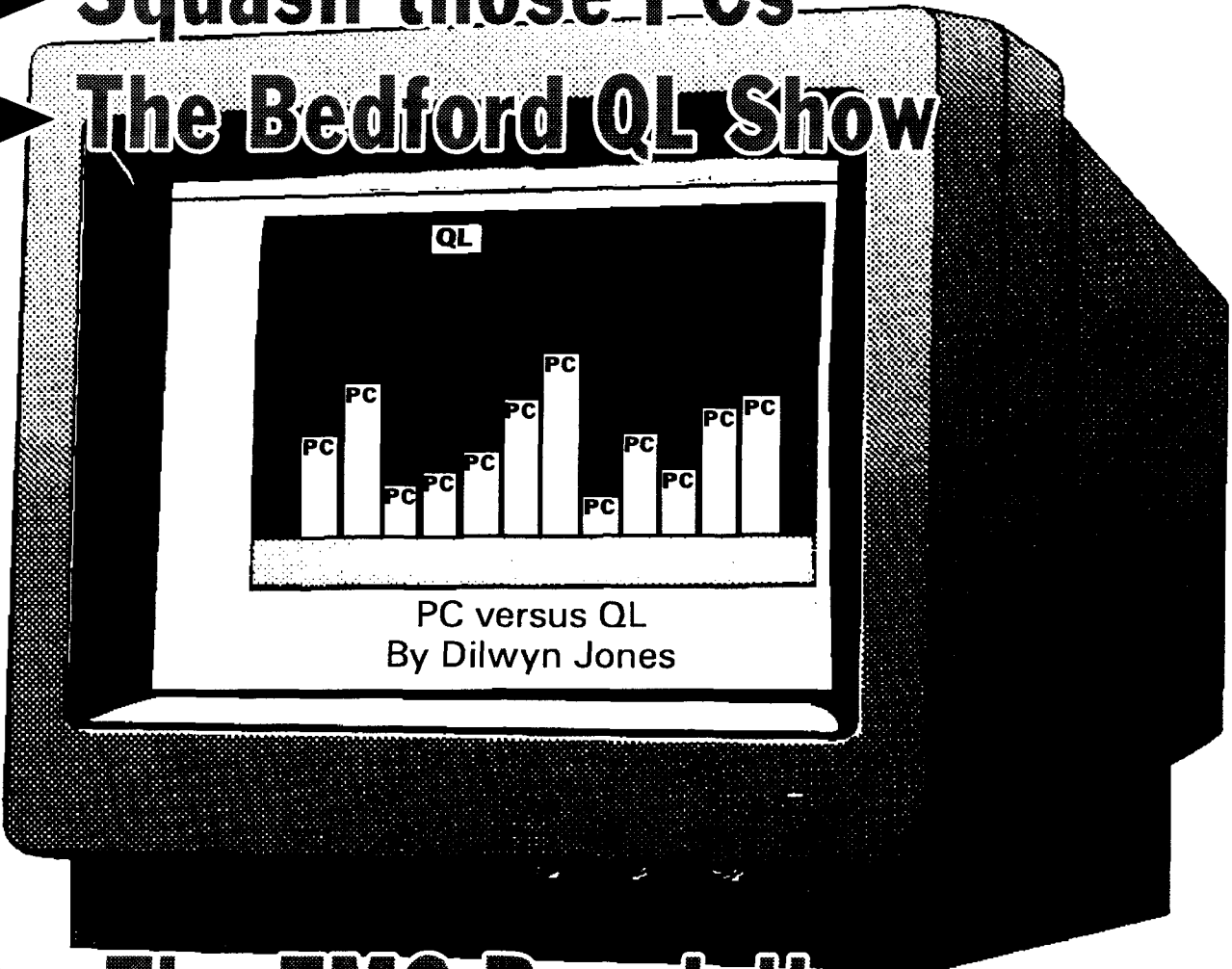

- **The EMC Regulations**
John Taylor investigates
- **Double the speed of your QXL**

QL Today

German office & Publisher:

Jochen Merz Software
Im stillen Winkel 12
47169 Duisburg
Germany

Tel. +49 203 502011
Fax +49 203 502012
Box1 +49 203 502013
Box2 +49 203 502014

English office:

Miracle Systems Ltd.
20 Mow Barton
Yate, Bristol
United Kingdom BS17 5NF

Tel. +44 1454 883602
Fax +44 1454 883602

Editor:

Dilwyn Jones
41 Bro Emrys
Tal-Y-Bont, Bangor
Gwynedd
United Kingdom LL57 3YT

Tel. +44 1248 354023
Fax +44 1248 354023

QL Today is published bi-monthly, our volume begins on 15th of May. Subscriptions begin with the current issue at the time of sign up. Subscription rates are as follows:

Germany	DM 70,-
England	DM 60,- or £25
Rest of the World	DM 70,- or £30

Payment in DM (drawn on a German bank) can be made by either Cheque or Euro-Cheque, Payment in £ (drawn on an English bank) can be made by Cheque. Cheques should be made payable to Jochen Merz Software (German office) or Miracle Systems Ltd. (English office).

Credit Card holders may subscribe by either calling or sending their Credit Card number and Expiry date. Credit cards will be charged in DM (German office) or in £ (English office).

We welcome your comments, suggestions and articles. YOU make **QL Today** possible. We are constantly changing and adjusting to meet your needs and requirements. Articles for publication should be on a 3.5" disk (DD or HD) in ASCII, Quill or text87 format. Pictures may be in _SCR format, we can also handle GIF or TIF. To enhance your article you may wish to include Saved Screen dumps. PLEASE send a hardcopy of all screens to be included. Don't forget to specify where in the text you would like the screen placed.

Article and Advertising DEADLINES are as follows:

Issue 1: 15 April	Issue 2: 15 June
Issue 3: 15 August	Issue 4: 15 October
Issue 5: 15 December	Issue 6: 15 February

QL Today reserves the right to publish or not publish any material submitted. Under no circumstances will **QL Today** be held liable for any direct, indirect or consequential damage or loss arising out of the use and/or inability to use any of the material published in **QL Today**. The opinions expressed herein are those of the authors and are not necessarily those of the publisher.

This magazine is copyrighted and all material published remains the property of **QL Today** unless otherwise specified. Written permission from **QL Today** is required before the reproduction and distribution of any/all material published herein. All copyrights and trademarks are hereby acknowledged.

Contents

- 3 Editorial
- 3 News & Updates
- 6 What happened to IQLR? - Stuart Honeyball
- 6 Renaming QL Disks - Graham D. Lutz
- 8 EMC in England - John Taylor
- 10 QXL2 - QL Hardware Emulator for the PC
- 10 More News
- 12 Bedford Show (or so) - Tony Firshman
- 13 Beginner's Basics Part 2 - Stuart Honeyball
- 15 From Perfection to LINEDesign
- Geoff Wicks
- 18 The QL's mobile Friend - The Cambridge
Z88 Portable Computer - Bill Richardson
- 20 PFB2PFF - A Review - Dilwyn Jones
- 22 How to visit a QL show - Jochen Merz
- 24 PC versus QL - Dilwyn Jones
- 26 How we produce QL Today - The Editors
- 27 Rectification
- 28 QDESIGN fix - Jochen Merz
- 28 Disk Drive News & Comment - D. Jones
- 30 Speedup your QXL - Terry Harman
- 32 QL Service List - Part 1 - Robert Klein
- 34 GO - Jochen Merz
- 34 PIP in Progress - Mark Knight
- 36 Small Ads
- 36 SERNET - Jochen Merz
- 38 QPC News - Albin Hessler
- 38 The BASIC Linker - Wolfgang Lenerz
- 40 QL Club - Mike Keneally
- 41 QL Writer's Package - Gary Norton
- 44 A Trip to Boston - Albin Hessler
- 48 The Genealogy Bug - Chris Boutal
- 50 Black Hole - Norman Dunbar
- 55 Q-Draughts - Dilwyn Jones

Advertisers

in alphabetical order

Jochen Merz Software	29
Miracle Systems Ltd.	11
PROGS - Van der Auwera	35
QBOX USA	15
QBranch	23
Quanta	37
Qubbesoft	5
W.N. Richardson (EEC)	19
TF Services	39
S.J.P.D. Software	46
Geoff Wicks	17

The release version of Simple Mailmerge now includes extensive data selection facilities (see the screen shot) in addition to the features described in issue 1 of QL Today.

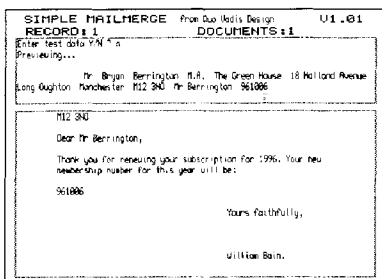

QUO VADIS DESIGN Catalogue

Issue 2 of the Quo Vadis Design software catalogue is now available, giving full details of the extensive range of programs available together with version numbers (helpful when trying to decide if it is time to update your software). The printed catalogue is 20 pages long, includes descriptions of all programs, and is available free of charge to anyone who contacts Quo Vadis Design by letter, fax, telephone, or email.

Quo Vadis Design now has a World Wide Web site at:

<http://ourworld.compuserve.com/homepages/qvd/>

Their QL software catalogue is also available from this site.

Quo Vadis Design, 57 Shaftesbury Road, Romford, Essex, RM1 2QJ, England.

Tel/Fax: (01708) 755759.

Email: 101366.3534@compuserve.com

News from Bill Richardson

Bill Richardson of W. N. Richardson & Co reports that he still has a good stock of the Z88 portable computer and various accessories, including file transfer software and cables for the QL and other computers. This little notebook computer has been quite popular with Sinclair devotees, because its small size, quiet keyboard and good battery life makes it an ideal travelling companion to save lugging an entire QL kit around with you. See the Z88 article in this issue.

W.N.Richardson & Co., 6 Ravensmead, Chalfont St Peter, Buckinghamshire, SL9 0NB. Tel/Fax: 01494-871319

NEWS FROM GEOFF WICKS STYLE-CHECK UPGRADE

Buyers of STYLE-CHECK version 2.00 (i.e. purchased before April 1996) are entitled to a free upgrade to the current version 2.02. Most will have been sent the upgrade automatically, but any user who has not received the new version should contact the author with proof of purchase. This

can be either a photocopy of the supplier's invoice or the return of the master disk.

SOLVIT-PLUS 2 COPYRIGHT CLARIFICATION

The SOLVIT-PLUS 2 disks contain both copyright and public domain material. Disk 1 contains the copyright material and may not be freely copied. The other disks supplied with the programme comprise public domain word lists.

SOLVIT-PLUS 2 WORD LISTS

Since the publication of SOLVIT-PLUS 2 the range of available languages has increased. As the word lists are from public domain sources, they are available to any QL user for a small fee to cover copying and administration costs. The currently available languages and size of the largest word list for each language are as follows:

Danish (23,000) Dutch (195,000) English (253,000) French (140,000) German (156,000) Italian (60,000) Norwegian (61,500) Spanish (86,000) Swedish (23,500)

Being from public domain sources the quality of the lists varies. Detailed information over the lists and the price can be obtained from the author of SOLVIT-PLUS 2.

Geoff Wicks, Bertrand Russellstraat 22, 1097 HL Amsterdam, Netherlands. Tel: (31) (0)20 682 1521.

QUBIDE

Ron Dunnett informed us that the current version of the Partition Program is 1.06 (last QL Today said it would be 0.09) - sorry about that mistake.

Black Knight 3D

François Lanciault is working on a 3D display version of the chess program called BlackKnight. It has got many other additional features compared to the existing version, which you will like. You will find more information about availability and upgrade prices in QL Today as soon as we know.

QBRANCH NEWS

QBRANCH has just released a new book "Archive made easy", written by Bill Cable. For £20 you get a book (84 pages) plus a disk containing programs. For the address see the QBRANCH ad. ■

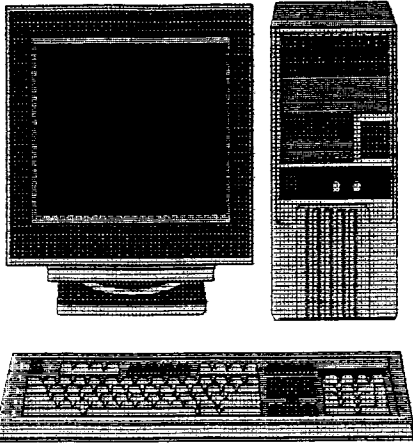

Q.L. Mini Tower Kit

The QL Mini Tower Kit comprises of the following components:-

- 1 - PC Mini Tower Case complete with 200 watt P.S.U.
- 1 - QPlane powered back plane.
- 1 - Sinclair QL Motherboard (JM or JS ROM Version).
- 1 - 8 pin DIN chassis socket (Monitor connection).
- 1 - 5 pin DIN chassis socket (Keyboard connection).
- 2 - 3.5mm jack sockets (QL Local Area Network connection).
- 1 - Di-Ren Keyboard I/Face + PC Keyboard.

All the above fully fitted into the PC Mini Tower Case.

£180.00p (JM Version) £190.00p (JS Version)

£20 PX for JM QL £30 PX for JS QL £32 PX Keyboard I/Face £18 PX Keyboard



PD & Shareware Software



Over 70 Disk's of Public Domain & Shareware Software for the Sinclair Q.L. Psion Xchange V3.90L, C68 'C' Compiler V4.20, QL Emulator (AMIGA) V3.23, Molecular Graphics V5.12, LineDesign 2 Demo, MicroEmacs V3.11, Page Designer 3 Demo, Climes.



LineDesign 2 EZ Clip-Art Collection 1



Over 100mb of Clip-Art files on a SyQuest 135 EZDrive Cartridge. These files will all load directly into LineDesign 2. Various themes are catered for such as Food, Backgrounds, Cartoons, Transport etc etc. Catalogue of Thumbnails is included so you can easily find the picture that you need.

£35.00p inc Cartridge & Catalogue

Inclusive of P&P (UK) +5% (Europe) +10% (Rest of World)



QUBIDE QL AT/IDE Interface

Allows you to connect modern AT/IDE Hard Drives to your QL. A massive amount of storage space can now be made available for your programs and files. Compatible with SGC, GC, TC and most memory expansion systems for the QL, also Minerva and SMSQ/E compatible.

£65.00p

fully inclusive of P&P (UK)
+5% (Europe), +10% (Rest of World)

SyQuest EZDrive 135 IDE Removable Medium

Affordable unlimited storage, speed and reliability of a hard drive. Compact with 3.5in portable cartridges. Compatible with QUBIDE. Can be used as Master or Slave. Faster than a CD ROM Drive. Cartridge holds 128MB equivalent to 190 DS/DD Diskettes.

EZDrive Unit ~~£165.00p~~ £135

EZDrive Cart £18.00p

Inc P&P (UK) +5% (Europe) +10% (Rest of World)

AT/IDE Hard Drives

A selection of new and used AT/IDE Hard Drives compatible with QUBIDE available. All Capacities from 40mb upto 850mb. Please ring or write for current stock availability.

QPlane

QPlane is a powered back plane for the QL, primarily designed to be used in conjunction with a PC Mini Tower Case and a PC PSU. QPlane has 2 power connectors known as P8 and P9 which marry up with the special power connectors of the PC PSU to supply all the power requirements for your QL and expansion units. QPlane has 3 expansion slots.

£25.00p

Fully inclusive of P&P (UK)
+5% (Europe), +10% (Rest of World)

QUBESoft P/D

38, Brunwin Road, Rayne, Braintree,
Essex. CM7 5BU. U.K.

Tel: +44 (0)1376 347852 Fax: +44 (0)1376 331267

E-Mail: 101634.776@compuserve.com

What happened to IQLR?

Yates, United Kingdom - Stuart Honeyball

It is a sad fact that from time to time, even in the QL market, a trader takes peoples' money and then ceases trading. I sincerely hope, and looking at the other QL traders am sure, that this will not happen again. I do not know for certain if the subject of this article is guilty of any wrong-doing at all, so I hope you won't assume I have pronounced him "guilty without trial", as everyone is innocent until proven guilty, but here I will report the facts as I am aware of them, in an effort to pass on as much information as we have available on the subject. The person I'm referring to is, of course, Bob Dyl, publisher of the now defunct IQLR magazine. In the Spectrum and early QL days Dyl ran the English Microconnection which mainly supplied items to Sinclair users in the USA but this ceased when he had his first heart attack and Dyl was then out of the market for a few years.

From the readers point of view IQLR was a good magazine. It started off 5 years ago with just a handful of pages and recently peaked at about 70 pages. As time went on more good articles were produced by a number of knowledgeable writers and more traders advertised in it. As an editor Dyl had the literary and artistic skills necessary to make a professional magazine. Surely a recipe for success? Well, you would have thought so according to the ever rising subscriber numbers that Dyl reported reaching about 2400 in August 1995. But there was something wrong. The concensus among the advertisers was that the response to adverts just wasn't what one would have expected from such a large number of readers. Those who advertised in the Quanta magazine, with a subscriber base of about 1500 at the time, found a better response there. I also wonder at my own naivety. Dyl used to send some of the magazines to myself in Britain to send out because of the lower postage rates; obviously a sensible and prudent course of action. In September 1995 I posted just 382 addresses to Britain, continental Europe and elsewhere. Where did the other 80+% go? (In my experience Britain and continental Europe account for about 90% of the QL market.)

On Monday 29 April 1996 I heard through the grapevine that Dyl had had another heart attack and was no longer going to publish IQLR. It is essential for the QL community that there is a centre of focus, i.e. a general magazine like IQLR, so after discussing it with other traders I suggested to Dyl that Jochen Merz and I could take it over.

Part of the deal would be that we would get some of the subscription money so that we could supply subscribers with issues due to them. This way everybody would be happy - subscribers would get all the issues they had paid for and Dyl would have no liabilities. As it happened Dyl told me that there was no money in the account. This was surprising since about 1/3 of the subscribers had just renewed and most of the advertisers, including Jochen Merz and myself, had just purchased a year's worth of advertising in advance which should all total about \$10000. Also, we were previously led to believe that money paid to IQLR had gone into an escrow account in order to protect the magazine.

Jochen Merz worked day and night and successfully created a new magazine (the issue prior to this one) from concept to printing in just 2 weeks. (I can attest that Jochen really did burn the midnight oil by virtue of the fact that on at least 2 occasions I received faxes sent at 3 o'clock in the morning!) This was no mean feat but was necessary because we were about to go to the annual QL meeting in the USA at that time. Consequently the American users were the first to see QL TODAY. Dyl was offered space in the magazine to comment on the situation but declined. Whilst in the USA we obtained from Dyl a mailing list of the current IQLR subscribers - a disappointing 366 - and some unpublished articles but, of course, no money.

Both Jochen and I decided we would share the loss with the subscribers so chose to give QL TODAYs to subscribers with outstanding IQLR subscriptions purchased through us and to others we would sell 1/2 price issues to substitute for the IQLRs they had lost. This in no way reduces Dyl's liability and so if you are owed issues you are at liberty to write to Dyl and inform him of the amount of your subscription you consider he owes you. Meanwhile we intend to constantly improve QL TODAY for the benefit of all QL users and look forward to a positive future. ■

Renaming QL Disks

Golcar, United Kingdom - Graham D. Lutz

Whilst this is not exactly a unique programming exercise, it is one which I feel many beginners will find interesting. For the more adventurous programmer, it makes an ideal platform for a pointer driven program, especially as the program outlined below can cater for any density of disk.

The disk name is found in the first sector of the first track on the first side. As with most things connected with computers, the first track is labeled zero, as is side one, so we are therefore looking for:

SECTOR 1 of TRACK 0 SIDE 0

To read this sector, we need to use **DIRECT SECTOR ACCESS**.

Direct sector access

To use direct sector access requires that your disk interface has the requisite software. I will assume that all you readers out there have a Trump Card or (Super)Gold Card and can therefore open a device with the name:

*D2D

If you cannot use this name, consult the manual for your disk interface and use any alternative that may be supplied on the interface ROM.

The (Super)Gold Card supports 3 densities of floppy disk, and therefore has 3 names for direct sector access, these are:-

*D2D For double density disks (720K).

*D2H For high density disks (1440K).

*D4E For extra high density disks (3200K).

We can test this with a simple superbasic program:

```
10 OPEN#3, 'FLP1_*D2D'
20 GET#3\1, sector$
30 PRINT sector$(5 to 14)
40 CLOSE#3
```

Line 10 opens FLP1_ for direct sector access on a double density disk. The name has to be in quotes, as the '*' is an 'illegal' character for a QDOS filename.

```
10 REPEAT loop
20 CLS
30 INPUT;"Enter density (d,h,e): ";density$
40 IF NOT density$ INSTR 'dhe' OR LEN(density$)>1:NEXT loop
50 IF density$='d':density$='*D2D':EXIT loop
60 IF density$='h':density$='*D2H':EXIT loop
70 IF density$='e':density$='*D4E':EXIT loop
80 END REPEAT loop
90 OPEN#3, 'FLP1_&density$
100 GET#3\1, sector$
110 PRINT\\"Current disk name is: ";
120 UNDER 1:PRINT;sector$(5 TO 14):UNDER 0
130 INPUT\\"Change current name (y/n): ";yn$
140 IF yn$=='y'
150 REPEAT newname
```

Line 20 uses the TK2 command GET to fetch the first sector of FLP1_ and assigns it to the string variable sector\$. We don't need to use any formulae for finding the side and track, as multiplication by 0 equals 0 !

Line 30 prints characters 5 to 14 of sector\$. The sector is actually 512 characters in length in this example, but we only want the 10 characters that make up the disk name.

Line 40 closes channel #3.

To change the name, we simply need to substitute the old name with a new one and re-write the sector back to FLP1_. Delete line 40 and add:

```
40 REPEAT newname
50 INPUT;"Enter new name: ";newname$
60 IF LEN(newname$)<=10:EXIT newname
70 END REPEAT newname
80 newname$=newname$&FILL$(' ',10-LEN(newname$))
90 sector$(5 to 14)=newname$
100 PUT#3\1,sector$
110 CLOSE#3
```

Line 40 starts a REPEAT loop.

Line 50 asks for input of the new name.

Line 60 checks that the name is 10 or less characters long, and if so exits the loop..

Line 70 ends the REPEAT loop.

Line 80 ensures that the name is always 10 characters in length by padding with spaces if necessary. This ensures that sector\$ is still 512 characters long when written back to disk and that only the name has changed.

Line 90 overwrites the old name with the new.

Line 100 uses the TK2 PUT command to write the sector back to disk.

Line 100 closes channel #3.

All we need to do now is add a few lines to pick densities and we have a working multi-density disk renaming program:

```

160 INPUT\ "Enter new name: ";newname$
170 IF LEN(newname$)<=10:EXIT newname
180 END REPEAT newname
190 newname$=newname$&FILL$(' ',10-LEN(newname$))
200 sector$(5 TO 14)=newname$
210 PUT#3\1,sector$
220 END IF
230 CLOSE#3
240 STOP

```

A word of warning is called for here, if you pick the wrong density QDOS will keep trying for a while before an error is produced!!

Obviously, this program is just the bare bones, and I leave it up to you to customise it as you like.

Happy QL'ing ■

EMC in England

Grantham, England - John Taylor

Following the statement on the Bulletin Boards, repeated in the September edition of Quanta, by Tony firshman informing all and sundry that it would be a CRIMINAL OFFENCE to use the QL and like machines once the EC directive on ElectroMagnetic Compliance became law on the 1st of January 1996, I undertook to ascertain just what the directive on EMC was about.

My first move was to the Lincolnshire Trading Standards Office who were very helpful about all manner of EC legislation but knew nothing about the EMC directive. I later found out that this would be their responsibility as the Government had decided that the enforcement should be at local level and that the Trading Standards Office in local Government would be adequate.

The Trading Standards Office did however give me some telephone numbers which they thought might be helpful. One of these was the Department for Trade and Industry dept. concerned with electrical equipment. A telephone call to them and yes they did know about the EMC directive. They assured me that I would not be going to jail for using my QL as the directive was NOT retrospective. All apparatus manufactured prior to 31st December 1995 was therefore exempt from the legislation.

The D.T.I. sent me some pamphlets, only one of which had any bearing on the subject. This one dealt specifically with EMC. It was called Electromagnetic Compatibility, Guidance Notes on UK Regulations. Published May 1995 reference URN 95/683.

Consisting of some 25 pages the guide tends to make use of generalisations and is rather short on

specifics. It is very specific however about the penalties for failing to comply. Imprisonment for a term not exceeding three months, or a fine not exceeding £5000, or both. It is also very specific about what documentation accompanies the apparatus and what markings are required. The CE marking will be used throughout the EEA. A quick trip into Dixon's, who knew nothing of EMC, disclosed that the CE marking requirements were in some use, especially on imported goods.

My concern being with the scope of the act rather than the markings required by the act I searched the document looking for more tangible guidance.

It would appear that the act was accepted as UK law on the 30th June 1992 as it refers to the existing National Legislation in force on that date, but I must admit that is only a guess. The law does allow for a transition period to 1st January 1997 after which the markings become mandatory. Compliance with the EMC standard is required from 1st January 1996.

Studying the guide revealed the following, but this again is only my interpretation. Parts are outside the act. Stock inside the distribution chain at the 31st December 1995 is also outside the act. Radio Amateur apparatus which is not available commercially is exempt. Certain medical devices are exempt. Apparatus to be used in a sealed electromagnetic environment is exempt but it must be accompanied by instructions that the apparatus is only for use in a sealed electromagnetic environment. Spark - ignition engines covered by another directive are exempt as also are Telecommunications terminal equipment likewise covered by another directive.

The general requirements of the directive are:

1. The essential 'protection' requirements;
2. The conformity assessment requirements;

3. The affixing of the CE marking by the manufacturer or his representative, eg importer; and
4. The issuing of an EC declaration of conformity.

The conformity assesment can be one of three ways:

1. Self certification. This is the simplest. The manufacturer choses a relevant standard chosen from an EC list and manufactures to that standard. He completes a declaration of conformity and places the CE marking on his product.
2. Technical Construction File. The manufacturer keeps a technical construction file on his product which he submits to a competant body for assesment. (There is a separate document covering the requirements of this method.)
3. EC type-examination route. This route requires a Notified body to issue a certificate of approval. This method is intended for use only with radio transmitting equipment, they do not have either of the other two options.

The declaration of conformity if using the self certification method.

This, if issued in the UK, shall:

1. Be in English
2. Give the name and address of the responsible person, and if not, the name of the manufacturer
3. Bear the date of issue
4. Give particulars sufficient to identify the equipment
5. State the numbers and titles of the relevant EMC standards applied by the manufacturer
6. Certify that the apparatus to which the declaration relates conforms with the protection requirements of the EMC directive

Technical Construction File Method, Declaration of Conformity

This is as for the self certification method but with the following addition:

The declaration must identify the Technical Construction File relating to the apparatus and give the name and address of the competant body which issued the report or technical certificate, the date and any reference number applied.

Also included was a two page document listing regional EMC clubs and their secretaries. The nearest to me was Rolls Royce at Derby. I contacted them but I seemed be at a disadvantage as I was not a member and they could not answer my question anyway. (The question follows later.)

I have recently received a further D.T.I. document URN95/785 published August 1995 called

Minimising the cost of meeting the EC directive on EMC. This refers in the main to meeting the documentation requirements which seem to have a very high priority with the D.T.I. Anyway it wasn't much help.

A Quanta member living in Barnet, Patrick H. Brown, wrote to his MP Sir Sydney Chapman who subsequently wrote to Ian Taylor MBE MP, Parliamentary Under Secretary of State for Science and Technology and very kindly Patrick has faxed me copies of the correspondence.

Ian Taylor provided the information that the original and amending directives be came part of UK law under Statutory Instrument S11992 No 2372 which came into force on 28th October 1992. He also confirms that all existing equipment is exempt from the directive and that equipment already in the supply chain at 31st December 1995 is also exempt and that there is no time limit on the disposal of such stocks.

I wrote to Patrick thanking him for his support and asked him to submit the following question to his MP who seems to be very co-operative. Though I wrote in the first week in November I have not as yet received a reply.

The all important question which I and many others would like answering is:

Can I manufacture and supply an apparatus which is intended to enhance existing equipment such as the BBC computer, the Commodore or the QL computer but only maintains the status quo regarding EMC?

To put it simply, if my equipment improves the computer without adding significantly to the electromagnetic radiation am I within the law? It may be that the equipment I seek to enhance does not comply but is exempt due to age but as I can do nothing to make it comply, where does my responsibility end?

In early December I wrote describing the problem to an Edinburgh member, George Gwilt, who had called me expressing a wish to intervene on behalf of Quanta with Malcolm Rifkin MP and as yet no reply has been recieved.

Graham Worsnop wrote in the October '95 issue of Quanta and did not leave it at that. He contacted the I.M.E.E. of which he is a member and they recommended that he writes to the New Electronics magazine as they are they were involved in the D.T.I.'s awareness to EMC campaign. They couldn't answer Graham's question but they passed the letter on to Nigel Harvey of SGS EMC Services.

Here is an extract of Nigel Harvey's reply:

"PC 'add-on' boards which are made available to an end user and which have a direct function intended for an end user are widely regarded as "apparatus" under the terms of the EMC Directive. As a result from 1.1.96 new stock will need to comply and bear the CE mark.

In the case of products for which no compliant host in which they can be tested is available, the situation is less clear. In the opinion of SGS, these should be tested within the non-compliant host, if it can be shown that the add-on does not significantly degrade the EMC performance of the host, then it is reasonable to argue that the add-on is itself compliant."

I have a strong feeling that this is the nearest we are going to get to an official ruling on EMC and additions to non-compliant equipment until such time as the law courts are required to make a ruling.

It is most unfortunate that the act did not specify on this matter but was very specific as to the penalties for non-compliance. ■

QXL2 - QL Hardware Emulator for the PC

Miracle Systems have relaunched the QXL with a higher clock rate and are calling it the QXL2. The QXL2 has a 25MHz clock whereas the old QXL's was 20MHz. It is available with either 4M or 8M RAM fitted; a 4M QXL2 can easily be upgraded to an 8M by simply fitting the chips into the empty sockets on the board. There are upgrade deals available for GOLD CARD or SUPER GOLD CARD (Miracle Systems or Quanta) owners.

The 25MHz clock gives an increase in application program speed of about 35% rather than the expected 25% for the same reason that the GOLD CARD and SUPER GOLD CARD appear to go faster than they should. The processor is interrupted at the same regular rate to trigger the scheduler, etc. regardless of clock rate. The time that this interrupt routine takes to execute is reduced by the increased clock rate and therefore leaves more time for the application to run. This means the application is not only running at a higher clock rate but is also given more time between interrupts to actually run and so gets a double boost in speed.

The reason why Miracle Systems stopped producing the QXL last year was not due the EMC

Directive as has been rumoured since it is a compliant product but because the cost of the parts, namely the processor and memory, just went too high. At this point it seemed like a good idea to make use of the processor and memory already fitted to GOLD CARDS and SUPER GOLD CARDS and so the concept of the QXL GOLD was mooted. The QXL GOLD was to have been a bridge board allowing either a GOLD CARD or SUPER GOLD CARD to be plugged into the PC. Before the development of this product was complete faster QXL parts started to become available at lower prices and so the QXL GOLD was axed and the QXL revived as the QXL2. This has got to be good news for the user since the processing power of the QXL2 is about twice what he would have got from a QXL GOLD and SUPER GOLD CARD combination.

For more information see the Miracle Systems advert. ■

News from TF Services

Minerva

Minerva V1.98 is under preparation. No major changes over V1.97. V1.98 now allows Qshang to run on a machine fitted with Minerva.

superHermes

SuperHermes is compatible with the Alps Glidepoint mini graphics tablet. If there is a demand for such a product, Tony Firshman says he could import some from the USA for approximately £50.00. Contact TF Services for further details.

superHermes/Qubide news

A version of the Qubide IDE interface rom (V1.41) is being developed to quick boot from data stored in the superHermes EEPROM - this is especially useful for SMSQ-E users. The change means that you don't have to wait so long for the Qubide to go through its startup sequence every time.

printer leads

TF Services is now manufacturing Serial-To-Centronics interfaces for both the QL and Z88. These will be sold by W. N. Richardson & Co. This is good news, since the original units manufactured by Miracle Systems Ltd are no longer in production. The new units will be based on the tried and tested boxed version of the Miracle Systems interface, but are a new surface mounted layout in a centronics plug case.

Miracle Systems

QXL2

(QL hardware emulator for the PC)

25MHz 68EC040

4M or 8M RAM

ISA half card

SMSQ and SBASIC

Very fast

2 year warranty

*** with 4M of RAM...£295.00**
(outside EU £255.00)

or your **GOLD CARD + £195**
(Outside EU £165)

or **SUPER GOLD CARD + £100**
(outside EU £85.00)

*** with 8M of RAM ... £395.00**
(Outside EU £340)

or your **GOLD CARD + £295**
(Outside EU £250)

or **SUPER GOLD CARD + £200**
(Outside EU £170)

14 day money-back guarantee

Prices include VAT (except outside EU) and postage

Please make sterling cheques payable to "Miracle Systems Ltd"

quote your Visa/Mastercard number and expiry date

Tel and Fax: +44 (0) 1454 883602

Miracle Systems Ltd, 20 Mow Barton, Yate, BS17 5NF, UK

News from QUBBESOFT P/D

DIY Toolkit

Ron Dunnett reports that Simon N. Goodwin, author of the DIY Toolkit series of articles, has kindly permitted Qubbesoft P/D to supply the entire range of DIY Toolkit extensions and articles on disk. The package will soon be available from Qubbesoft on 2 disks, at usual PD library charges (in other words, low cost). The package will only be available as a complete collection, making it easy for you to simply extract the parts you need.

Qubide news

At the time of writing, V1.40 of the Qubide IDE Interface ROM was available, with a possible V1.41 about to become available for superHermes users. V1.40 includes a disk containing V1.07 of the partition program, and the ROM itself allows for increased slave block handling performance, and a minor change to allow certain types of Quantum hard disk drives to be used with the system. V1.41 will allow users of the superHermes system to store certain startup data in the superHermes EEPROM, thus cutting down on the initialisation times, especially when SMSQ/E is used.

Aurora News

The long-awaited Aurora graphics card and replacement QL mother board from Croatian hardware designer Zeljko Nastasic is now at an advanced design stage, with a working prototype scheduled to make an appearance at the QL Traders Show in England on June 22nd. After that, four advanced prototypes would be built in the following months, and then Ron Dunnett will proceed to source components for assembly of fully working models, hopefully becoming commercially available either at the end of August or early in the autumn period. Design work was held up slightly by Nastasic's work pressures in his day-job in the middle of the year (working long hours etc). Ron stated that he was hoping for a price of £120.00 approx. for the combined graphics card and replacement motherboard, but this may change (up or down!) subject to final component and assembly costs.

News from W. N. Richardson & CO.

Printer Interface

Bill Richardson reports that serial to parallel conversion printer interfaces will soon be available again. The interfaces will be manufactured by TF Services, and will be available in QL and Z88 versions. Prices will be £29.00 for the QL version and £39.00 for the Z88 version, both prices include VAT.

Bedford Show (or so...)

London, England - Tony Firshman

Afficianados of shows will know (even if not by direct experience) that there is **always** a story to tell.

The one this time is about rain and rain and rain.....

We were warned by all and sundry before we (Stuart and I) left on our fold up bicycles that it had been raining for weeks - did we want a lift? **NO!**

he he - on that Thursday evening in Boston we had second thoughts. We landed to a dry Boston, but there were a few spots of rain. By the time we left the airport it was bucketing down. On with my leggings, kagool and spare 'waterproof' shoes. How clever I am (like the pieman) I thought.

We were hooted off the freeway by a pistol wielding cop - not the time we thought to tell him that we came out the only signposted way. Where is the road to Revere? I won't print his reply. The 'aarsoles' we heard from a lorry driver to the meek old lady driver 3 years ago was nothing. Welcome to America!

OK we found the services road, and sailed out of the Airport - to get immediately lost. Well it was raining and the great bike map (kindly provided by Al Boehm) showing the direct bike route to Bedford on the Minuteman railway (deceased) turned out to be on loo paper (really). We had to take very brief looks at it, as each time less would unfold. We took the drunken route to the start of the cycleway (ie try every blind alley and side turning and try to go in the opposite direction).

We asked a local resident (we **knew** we were close) - 'dunno'. It was at the end of his road. We carried on down the cycleway - but it ended. Is this the Minuteman cycle path (to some walkers actually on the path) - 'Never heard of it'

Went the wrong way up a bus station road (Look at \$50,000 dollar fine notice Stuart quipped <I noted later it was \$50.00 - exactly - not a cent more or less. Accurate chaps these Americans>).

Incidentally they love their signs. Not a moment passes without some detailed instruction on what to do, what not to do, what to think and not to think. You get the picture. They also like to quote the statute 236 sub-section 236a Article 9 1956 - even on no smoking notices.

Oh that reminds me. Have you seen the ludicrous questions on their visa waiver form. I do not kid:

Are you a terrorist?

yes no

Did you perform mass genocide between 1939 and

1945?

yes no

Well any self respecting terrorist or Nazi wouldn't lie would he/she.

Have you ever committed moral turpitude

yes no

(dunno really)

... and so on. They must think visitors are loopy (don't answer that one please) Stuart and I risked suicide by answering flippantly.

I put N/A against the genocide question (I wasn't born - just). Can't remember what Stuart put, but he must have fooled them.

Oh yes - back to the shoes. Yes they are waterproof - but against water from below. The water running down my **very** waterproof leggings ran straight in, and (yes you guessed it) didn't run out. Squelch Squelch.

Back to the trail; where was I. Oh yes the Minuteman railroad ran out in Jerry's Pond. Well it was in a derelict wasteground. 'Where are we' to a person at the bus shelter - 'in a playground'!

We started to try to find any useable bits of map. Any bits we found (all completely soggy and **very** fragile) that appeared relevant were stuck onto the bus shelter. Any others ended up in a papier mache ball. I then proceeded to assemble a vital jigsaw puzzle. There was a bit still missing - ah there it was on the **back** of a sliver, like a chameleon on another part of the Boston map. I found some dry A4 in my rucksack - and wonder upon wonders, a waterproof sealable map holder. Well no - but it was a plastic sealable container for Bill Richardson's precious Z88 keypads. Well what would **you** have done then?

Amazingly we not only had the schematic for most of the Minuteman but also the detailed map of the area of Boston we were in. Where is the bike path (to our incredulous American companion in the shelter) - 'Dunno'.

I guess they all thought we were mad and didn't want to get involved. 'We are going to Bedford' 'Neva hoid of it! Hrrmmm.

Went a bit further on - 'Where are we?' 'Dunno but I live just over there'

We were in fact about 5 minutes from Alewife where the Minuteman starts. This was 3 hours after leaving on the 30 minutes ride from the airport to the path. We were both beginning to feel frozen, wet, cold, hungry (will come to that later) - where was Al Boehm (-)#

Anyway we got to the path - and that was it. Straight riding all the way to Bedford - and we met only **one** other cyclist. No wonder no-one has heard of the path (see later).

Got to Bedford Ramada Inn about 10pm. We looked like visitors from outer space (really) and the receptionist's face was a picture. You **cycled**... from **BOSTON** .. all the way ... and the mandatory 'What cycle path?'

Ah well - the best cycle path we had ever come across - far far better surface than the roads. Pity no-one uses it (see later).

We squeezed ourselves dry, de-thawed in baths, and laid out our clothing, steaming, on every available surface. Plugged my **dry** switched mode power supply in - it blew (Great diagnosis by Don Waltermann at the show - and one power transistor and a fuse when I got home got it going).

To reception - 'Where can we eat' '3 miles down the road' 'Are you kidding!' We walked for what seemed like miles to the local supermarket (a mall opposite the hotel with a motorway speed car park) for cold soggy (a par for the course) fried chicken. I had been dreaming of a **large** steak and fries all the way from Boston. Ah well, lets get drunk instead - 'Bar closes in 5 minutes'

< meeting happened here. **Very very** good but will leave the details to others>

I liked Al praying, during grace, to God for the future of the QL. Nice to have Him on our side <grin>. Robin and I got rowdy at the singsong (drunk at **last**).

Well the cycle ride home was pretty uneventful, but there were hundreds and hundreds of roller bladers on the way back. No wonder no-one knew where the 'cycle path' was. (It was called the Minuteman cycle path - honest)

It didn't rain at all. ■

Beginner's Basics - Part 2

Yates, England - Stuart Honeyball

Procedures and functions are the mainstays of structured programming. What they do is collect together lines of Superbasic constituting a sub-program which can then be called by a single meaningful name of your choosing.

Look at the following procedure:

```
10 DEFine PROCEDURE Multiply(x,y)
20  x=x*y
30 END DEFine Multiply
```

The procedure **Multiply** has to be given 2 inputs, x and y. The variable x is then multiplied by y and the result put back into x. You could call it with the following addition to the program:

```

40 :REMark This is a blank line to separate
procedure from rest of program
50 n=3
60 m=4
70 Multiply n,m
80 PRINT n,m

```

These lines firstly set the value of variables `n` to 3 and `m` to 4, then the procedure `Multiply` is called causing the values of `n` and `m` to be temporarily passed into `x` and `y`, the multiplication carried out, then the procedure is left and the end values of `n` and `m` are printed on screen.

There are several points to note:

1) The formal parameters (i.e. the ones in the procedure definition line, `x` and `y` in this case) are put inside a pair of parentheses and are separated by delimiters, usually commas.

2) The actual parameters (i.e. those used in the calling, `n` and `m` here) are not put in parentheses.

3) In this case the formal parameter `x` is called by reference because its value is updated by the procedure whereas formal parameter `y` is called by value.

4) The body of the procedure is indented for easy reading.

Functions have a lot in common with procedures. Their difference is that they return a value. This means that whereas a procedure is a statement in itself, a function is an expression.

Look at the following function:

```

90 :
100 DEFine FuNction Product(x,y)
110 LOCal Product_x_y
120 Product_x_y=x*y
130 RETurn Product_x_y
140 END DEFine Product

```

This function also multiplies 2 values together but, rather than updating an actual parameter, passes the result back to where it was called e.g. if you typed in at #0, i.e. in immediate mode, the following:

```
PRINT Product(5,7)
```

then 35 would be printed to the screen.

Note that with functions the actual parameters have to be supplied within a pair of parentheses. Also the `x` and `y` are completely independent of the `x` and `y` in `Multiply` - they are said to be in scope only during the execution of their own procedure/function. The variable `Product_x_y` is used only during the execution of `Product` and so is local to it and declared thus. Its scope is the same as the formal parameters.

We could use `Product` in the definition of `Multiply` and rewrite it like this:

```

10 DEFine PROCedure Multiply(x,y)
20 x=Product(x,y)
30 END DEFine Mult

```

and everything still works.

Alternatively we could write `Product` in terms of `Multiply` like this:

```

100 DEFine FuNction Product(x,y)
110 LOCal Product_x_y,Temp_x
115 Temp_x=x
120 Product_x_y=Multiply(Temp_x,y)
130 RETurn Product_x_y
140 END DEFine Product

```

(The new variable `Temp_x` has been added so that `Product's x` is not updated by `Multiply`).

But if we had both alternatives together, i.e. `Multiply` defined in terms of `Product` and `Product` defined in terms of `Multiply` then when you call `Multiply` it would call `Product` and, in turn, it would call `Multiply` which would call `Product...Help!` There's no way out and the program has crashed.

Where a procedure or function calls itself either directly or indirectly, as above, it is said to be recursive. When you use recursion you must provide for an end point. Suppose we want to write a function to reverse a string such that if you gave the function the string "ABCDE" then it would return "EDCBA". The function can be defined in terms of itself as follows: the result of reverse is the last letter of the string followed by the reverse of the remaining part. In other words, in the example here, the reverse of "ABCDE" is "E" followed by the reverse of "ABCD". The reverse of "ABCD" is "D" followed by the reverse of "ABC", and so on. The problem is that once you run out of letters there is no last letter and...crash. We need to look at the end condition which is where there is just a single character in the string supplied in which case the reverse is the given string. It is good idea also to be able to deal with the null string i.e. "". You can see that if the length of the string is less than or equal to 1 then the reverse is itself. So in Superbasic we have:

```

10 DEFine FuNction Reverse$(x$)
20 LOCal Length
30 Length=LEN(x$)
40 IF Length<=1
50 RETurn x$
60 ELSE
70 RETurn x$(Length)&Reverse$(x$(1 TO
Length-1))
80 END IF
90 END DEFine reverse

```

continued on page 58

From Perfection to LINEdesign

The Netherlands, Geoff Wicks

When you accuse a software house of making one of the most inaccurate statements in a QL manual, you do not usually intend it as a compliment. In this case I do. My award is made to PROGS for the opening sentence of the LINEdesign manual:

"LINEdesign v.2.00 was conceived primarily as a drawing program and, although you can put text on the page, the editing facilities are very limited.....".

I understand what PROGS mean by this statement. LINEdesign is not a DeskTop Publishing programme, but a drawing program. Nevertheless its text handling possibilities are one of its most popular features. You have only to look through the advertisements in this issue of QL Today to see the proof of this.

Unfortunately the LINEdesign manual does not offer a great deal of help on importing text. This shortcoming has been remedied by the Publisher Pack, which interfaces Text87 plus 4 with LINEdesign. Although this is the software combination most suitable for the first time buyer, there are QL users who are reluctant to purchase the Publisher Pack.

A survey in QL World, shortly before it closed, indicated that a half of QL users were still using Quill as their word processor. The non Quill users were divided equally between Text87 and Perfection.

Many Perfection users may prefer not to buy the Publisher Pack. Some will be reluctant to spend their money on a third word processor and others, having struggled to learn Perfection, will be reluctant to have to repeat this process with Text87. Perfection users should not despair. They can still import text into LINEdesign, although it is more hassle than using the Publisher Pack. My advertisements and information sheets are all prepared using LINEdesign and Perfection.

If you wish to interface Perfection with LINEdesign it is useful, for reasons that will become clear, to have the two programs multitasking and to use a ram disk for intermediate files. As LINEdesign is a pointer environment programme this is easily done. First load LINEdesign, then press Ctrl + C to enter SuperBasic and finally start Perfection with the direct command "Exec flp1_Perfection" or equivalent.

THE PERFECTION SETTINGS:

Although Perfection contains an export command (F3 I), this does not always give true ASCII text. This is because Perfection uses chr\$(206) to indicate the

WE SUPPORT SINCLAIR

QBOX USA

COMPUTER BULLETIN BOARD SERVICE

(810)254-9878

**We support *all* SINCLAIR COMPUTERS
(QL, SPECTRUM, ZX81, Z88, Thor, QXL)**

- Now in our 3rd year on-line round the clock since October, 1993
- Full message area and File Download areas
- We carry all popular SINCLAIR message areas from Europe
- Calls from 14.4k--300 baud are welcome
- QBOX - USA runs on a SINCLAIR QL with Super Gold Card, Hermes, QUBIDE, 200MB drive, USR sportster 14.4 modem

→ NO FEES CALL US

end of a paragraph, whereas ASCII text would just use a line feed (chr\$(10)). When LINEdesign sees a chr\$(206), it assumes that the end of the text has been reached. At most you will be able to import only one paragraph into LINEdesign.

There are two ways to get round this problem, but whichever one you use you will need to have the correct settings for Perfection. The left and indent margins should both be set to 1, you should use left justification and there should be at least one blank line between paragraphs as LINEdesign looks for 2 line feeds to determine the end of a paragraph. It is also advisable to have no highlighting such as bold, underlined or italic text.

The first way is to use the export command (F3 I), and then to run the saved text through the Stripsort program on the Perfection disk. This is easily done. Just load Stripsort and follow the instructions on the screen. Select option A for automatic unless you have highlighting in your text and then option O "Save without sorting".

The second way to save the text is via a printer driver. This is a simple printer driver as it needs only two pieces of information. Use the Create_Printer_Drive program to set the device/ file name as "Ram1_" and the end of line to "LF". You can load this driver into Perfection using F3 F3 F3 D.

When you transfer text from a QL word processor to another program, word processor or computer, the presence of a line feed at the end of each line can cause formatting problems after the text is transferred. Perfection gives you a way of getting round this. You can set the right margin to 1024, which means that, if your paragraph is not abnormally long, it becomes one long line of text. So set the Right margin to 1024, and then use F3 F3 E to reformat the text. When you have done this, print the text to either Ram disk or magnetic medium.

THE LINEDESIGN SETTINGS:

Before we go onto to the settings for LINEdesign, we need to look at the fundamentals of page design in any desk top publishing or drawing program. You should always think of your page in terms of a grid. The first thing to decide is how many columns your page will have. For an A4 page, 2 or 3 columns will usually be the most suitable. The page will need margins at the left and right hand sides and empty space or "gutters" between the columns. You should then decide how many rows or "page breaks" you

want on your page. There should be margins at the top and bottom of the page, but there are no gutters between page breaks.

If you are a LINEdesign user who has experience of Professional Publisher, this concept of page design will be familiar to you, because Professional Publisher had numerous grid commands that allowed you to set up different page designs. You could save these to disk as templates for future use. Unfortunately LINEdesign does not have this feature, although the Publisher Pack for Text87 users goes part of the way. LINEdesign does have a general grid command available under the Display menu obtained by pressing F5. This grid can be made as fine or as coarse as you wish.

When I import text from Perfection to LINEdesign, I make extensive use of this grid. On my information sheets I use a three column page. If I set the x and y spacing of the grid to 20, there are 30 grid columns on the page. As I need 2 margins and 2 gutters, I have $30 - 4 = 26$ grid columns available for my page columns. Unfortunately

26 is not exactly divisible by 3. No one has yet noticed that I cheat slightly, and hide this by placing illustrations in strategic places. In my QL-Thesaurus information sheet, I use 2 text columns of 8 grid columns each and 1 column of illustrations of 10 grid columns. The illustration to this article shows a LINEdesign screen displaying the top half of my Thesaurus information sheet with the grid superimposed.

KEEP IT SIMPLE

The first time you attempt to import text from Perfection it is best to keep it simple by just importing to one box. Text is added in the normal way by hitting the text icon and then choosing paragraph text by pressing <ENTER> or for mouse users DO. You draw the box for the text over the grid. Load the text from your ram disk file that you created from Perfection. As it is difficult to draw a box for the text exactly over the grid, after the text has been imported, it is sensible to line it up on the grid by using F3 S for the Snap to Grid Command. For extra fine tuning the grid could be made finer by changing the x and y separation from 20 to 10 or even 5.

At this stage you will probably discover that your text does not fit exactly into the box. However there is no need to panic, because this is where the versatility of LINEdesign's text handling comes to

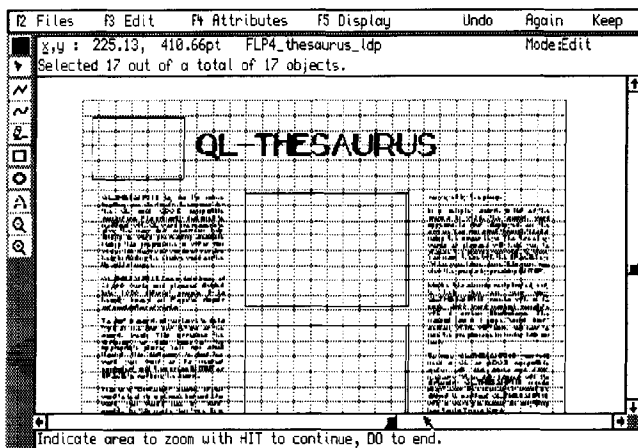

your rescue. Press TAB until the box is your current object and then press F4 to access the attributes menu. You now have numerous possibilities to alter the text so that it fits neatly into the box. You could increase or decrease the size of the font by one point size, you could alter the space between paragraphs, you could alter the leading (that is the distance between lines of text) or, if you are really desperate, you could change the font. Line Design keeps all the text imported into a box in memory, so that, if you make any alterations, you may have more or less of your text displayed than in your first attempt. You can continue experimenting until you get it just right.

NOW MAKE IT COMPLICATED

Things become more complicated when you want to load text into more than one box, when, for example, you have more than one text column. When you import text from Perfection you cannot let it flow automatically from box to box. You will have to import text into each box separately. Thus use the Line Design cursor and zoom commands to view the end of the text in your first box and make a note of the last few words of the text. Press CTRL + C to go back to Perfection and delete all the text up to this point. Now print the remaining text to ram disk, go back to Line Design and repeat the operation for your second box.

Three words of warning. Firstly, you should use the same settings for your second box as for your first. Secondly if you make any changes to your first box, this could change the amount of text in this box, so that you will have to delete the second box and begin it again. Do not worry about this, you will discover you can do it quickly and easily. Thirdly, if you use more than one box, you should ensure that the text in the two boxes is correctly lined up. This is done using the grid and the Snap to Grid command.

If you include illustrations on your page, you have even more possibilities to get the text to fit onto the page. It is easy to change the size of an illustration, to put a box around it or to add a caption at the bottom or at the side. You can also move the text up and down the column, but do not forget to check that the text is correctly aligned with the text in other boxes and to use the Snap to Grid command.

In practice importing text to LINEdesign from Perfection is less complicated than it appears when written down. As with most things in page design and desk top publishing, the best way to learn is to set aside a hour just to experiment. It will be an hour that you will enjoy, and will save your time and energy when you have to produce that important document in a hurry. ■

JUST WORDS!

Software for Writers and Word Lovers

CRUNCH, CRUNCH....

The QL has long had maths programs for the number crunchers, but only recently specialist software for the word crunchers.

If you are a writer, whether of an 80,000 word novel or of just the occasional report, you will like the QL WRITER'S PACK. This combines two programs, the QL's only thesaurus and the QL's only style checker, at a discount price.

If your preference is for word puzzles, either as a solver or a compiler, SOLVIT-PLUS 2 will give you hours of pleasure. Not only in English, but also in Danish, Dutch, French, German, Italian, Norwegian, Spanish and Swedish.

You could, of course, buy all three programs for the bargain price of £35.

The Complete Range:

SOLVIT-PLUS 2 <i>Dictionary for word puzzles</i>	£15
QL-THESAURUS <i>23,000 words in 1,000 groups.</i>	£15
STYLE-CHECK <i>Improves your writing style.</i>	£15
WORDS PACKAGE <i>(Solvit-Plus 2 + Thesaurus)</i>	£25
WRITER'S PACK <i>(Thesaurus + Style-Check)</i>	£25
ALL 3 PROGRAMS	£35

Available direct from the author, from QUO VADIS or from Q BRANCH.

Pay by sterling cheque drawn on UK bank, Eurocheque in guilders or International Postal Order.

(£5 = 13 guilders)

*Geoff Wicks, Bertrand Russellstraat 22, 1097 HL Amsterdam, Netherlands.
Tel: (31) (0)20 - 692 1521. Netherlands Bank: Postbank number 4111942*

The QL's mobile Friend - The Cambridge Z88 A4 Portable Computer

Bill Richardson



Editor's note: although QL Today does not normally include articles about non-QDOS based computers, we feel that both the Sinclair connection and the ease of use almost as a QL peripheral, plus the fact that quite a few QL users, myself included, own Z88s that the inclusion of this article is justified. Would you the readers like to see more articles about the Z88, or do you think it ought not to be covered in these pages at all? Why not write to let us know what you think.

The Z88 is of particular interest to QL users who need to use a computer away from their desk. There are two QUANTA PD programs that enable the transfer of ASCII text to and from a Word Processor, and one for Archive files. It is also possible to store Z88 data files in Z88 format on the QL disk system. There are also PCLINK, MACLINK, and similar programs for other computers.

The features that make the Z88 particularly handy are, almost instant access to the current Diary, Text, Database, or Spreadsheet. If turned 'OFF' or left to turn itself 'OFF', the Z88 returns exactly to what it was last doing when it is turned "ON" again. The word processor can produce well laid-out text, even in columns, & with styles.

The Z88 is particularly useful for producing quick notes on a printer: it takes no longer than the typing time plus the time to press four keys for immediate screen output to a printer.

A Printer Driver Editor very similar to the QL's Printer 'Install_bas' is provided.

The Z88 battery life (4 AA Alkaline cells) is up to 20 hours in use, and up to a year on stand-by. Battery life can be 'stretched' with the available PSU. If a PSU is not to hand an internal capacitor will keep the Z88 going for a short period whilst batteries are changed; there is a 'LOW BATT' screen warning.

The keyboard is positive, a sensible size, sealed and splash-proof.

A RS232 SERIAL PORT is provided and a Centronics adapter is available if required.

The Z88 uses PIPEDREAM, an excellent built-in integrated program for Word Processing, Database, and Spreadsheet which is friendly and competent using menus or shortcuts for speed. This is backed up with multi-tasking Popdowns for CLOCK, CALCULATOR, Organiser DIARY & ALARM, which can be called up during any work in progress.

Several tasks can be run concurrently, and each task remains as it was left and listed as a SUSPENDED ACTIVITY, so can be immediately revived. The Screen shows six lines of 72 characters width.

APPLICATIONS		SUSPENDED ACTIVITIES			
NAME	KEY	YOUR REF.	APPLICATION	WHEN SUSPENDED	CARDS
Diary	AD				
Pipedream	AP				
BASIC	AB				
Calculator	AC				
Calendar	BC				
Clock	AT				
			Pipedream	Today	10:06:58

Z88 MAIN DISPLAY

The Z88 has an IMPORT/EXPORT program for transferring files to other computers as well as one to act as a TERMINAL. This is VT52 compatible for connection to another computer or MODEM. For programmers BBC BASIC is also on hand. Various applications & programs can be run from plug-in ROM CARDS.

The Z88 Operating System (called 'OZ') is retained in an internal ROM. The working memory, & files are held in RAM giving rapid response, In addition to the working RAM of only nominally 32K, work can be held on one or two RAM CARDS plugged into two Slots 1. & 2., so this provides RAM.0, RAM.1, & RAM.2, where RAM.0 is the working area. Long documents (Your Book!) can be held in LIST FILES which will automatically load & unload files from the RAMs into the working area as required. The RAM capacity can be expanded up to 2Mb with the plug-in RAM CARDS. Z88s with 128k memory can be obtained.

As RAMS are dependant on sustained power input to the Z88, important data & programs can be stored securely on EPROM CARDS in Slot 3., or of course, transferred to the QL disk drive. EPROMS of different values up to 256k can be removed and exchanged at any time; and can also be switched between Z88s. Data saved on an EPROM is 'permanent' and in a stack so cannot be overwritten, only recalled from it's directory. If required or when full, an EPROM can be totally erased for reuse, with an available Eraser.

For Z88 users who have to carry out repetitive operations involving a lot of keystrokes or instructions it has a 'wizard' type recording system called 'CLI' (Command Line Interpreter).

The Z88 Manual is well written and solves most problems easily. There is also an independently written book, Z88 MAGIC which goes into more detail and is also intended for less experienced computer users. It gives HINTS and warnings about Z88 usage.

QXL users who would like a taste of the Z88 and who would like to improve their PCs further, can now get a Z88 emulator which runs on the PC. It is available from SJP software, on their disk number PCPD28. The emulator was written by H. A. van den Belt of Germany. [Editor] ■

SINCLAIR Z88

OFFICE/FAX 01494-871319 (EEC) *W.N. Richardson & Co.*

MOBILE: 0850 597650

6 Ravensmead
Chalfont St Peter
Buckinghamshire, SL9 0NS

THE IDEAL PORTABLE COMPANION FOR THE QL

THE CAMBRIDGE Z88 A4 NOTEBOOK

WITH BUILT-IN WORD PROCESSOR, SPREADSHEET, DATABASE, BASIC, CALCULATOR, CLOCK, ALARM, CALENDAR, & VT52 TERMINAL.

USES 4XAA ALKALINE CELLS (c.20 HOURS)

CAMBRIDGE Z88 A4 NOTEBOOK COMPUTER & ACCESSORIES

IT IS RECOMMENDED THAT ACCESSORIES ARE BOUGHT SOON AS THE PRESENT STOCK IS RUNNING LOW. NEW STOCK WILL HAVE TO BE REPRICED. ALL UK PRICES INCLUDE VAT.

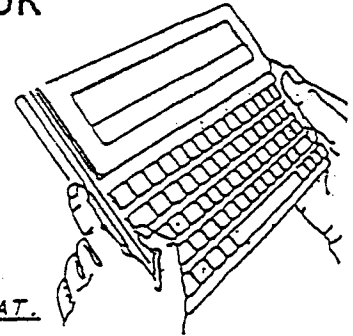

	UK.	USA.
<u>CAMBRIDGE Z88 COMPUTER.</u>	£99	\$130
2k RAMPACK	£16	\$22
128k RAMPACK	£28	\$37
512k RAMPACK	£60	\$80
1Meg RAMPACK	£120	\$160
32k EPROM PACK	£16	\$22
128k EPROM PACK	£22	\$30
256k EPROM PACK	£45	\$60
EPROM ERASER	£32	\$43
PARALLEL PRINTER LEAD	£22	\$30
SERIAL PRINTER LEAD	£18	\$24
MODEM	£90	\$120
MAINS ADAPTER (230vac; 6v, 500ma)	£15	\$20
TOPPER (PROTECTIVE COVER)	£12	\$16
CARRYING CASE	£16	\$20
'Z88 MAGIC' A BETTER USER HANDBOOK	£15	\$20
<u>FILE TRANSFER TO OTHER COMPUTERS</u>		
SPECIAL Z88-QL SERIAL LEAD	£10	\$12
COPY DISKS OF QUANTA PROGS IMP/EXP & ARCHIVE EXPORT	Each £2	\$2
PCLINK KIT (For PCs)	£25	\$33
Z88 TO MAC KIT	£30	\$40
Z88 TO BBC KIT	£15	\$20

UK PRICES INCLUDE VAT: USA PRICES DO NOT. FOR OTHER NON-EEC COUNTRIES

DEDUCT 10% FROM THE UK PRICES.

POSTAGE UK £5. EEC £15. USA £20. OTHER COUNTRIES £30.

ALL THE STOCK IS NEW AND IS WARRANTIED FOR 90 DAYS. IN THE EVENT OF REPLACEMENT BEING AGREED, BUT THE ITEM BEING OUT OF STOCK AT THE TIME, A REFUND WILL BE MADE PROVIDED THE ITEM IS RECEIVED IN GOOD CONDITION.

QL & PC COMPUTER USERS WILL FIND THE CAMBRIDGE Z88 ESPECIALLY USEFUL FOR WORK AWAY FROM THE DESKTOP. WITH TRANSFER PROGS DATA CAN BE SAFELY EXCHANGED WITH THEIR DESKTOP SYSTEM.

W.N.RICHARDSON & CO CONTINUES TO PROVIDE FULL SPARES AND SERVICES FOR SINCLAIR COMPUTERS. QL. & THE CAMBRIDGE Z88.

PFB2PFF - A Review

Tal-y-bont, Bangor, WALES - Dilwyn Jones

The quaintly named Pfb2Pff is a suite of C compiled programs to assist with the conversion of Adobe Type 1 fonts to Line Design (or more correctly, ProForma) format. There are 5 programs in all, plus 1 font used when printing out sample sheets for converted fonts.

The PC (wash my mouth out with soap!) public domain, freeware and shareware contains a large amount of fonts for both Adobe Type Manager (ATM) and TrueType fonts which can be used with most PC text and graphics software under Windows on the PC. Indeed, you can get CDs with thousands of fonts on them for only a very low cost. Shareware libraries will also sell you floppy disks with such fonts on them. Some are free, others are shareware, where you have to pay a modest registration fee for continued use of the material after a short 'trial' period. Wouldn't it be nice if QL Line Design users could also use this huge source of fonts? Well now we can. Or at least we can use the ATM (Type 1) fonts by converting with PFB2PFF.

The first and most important program is PFB2PFF itself. This converts the .PFB (Type 1) fonts into _PFF ProForma fonts. These are the native fonts used by programs like LineDesign, PFData and PFList from PROGS in Belgium. The ProForma native font format is unique to PROGS' software, but is fairly similar to the Type 1 format.

ADDKERN - This program adds kerning information (proximity and overlap information) to the font, where the equivalent .AFM file is available for the font which has been converted. The PC version of the font will have 2 or more associated files - the ones we are interested in are those with filenames ending in .PFB (the font itself) and the .AFM file, containing the metric information about the font. If the .AFM file is not available (sometimes the case with free fonts in particular), you can still convert it with PFB2PFF, although you can't use ADDKERN to add the kerning information to the font.

SHOWFONT prints a sample sheet showing the characters of a named font. The style and layout is similar to the font printouts in the manuals which PROGS supply with their ProForma-based software, such as Line Design. These printed copies are essential if you have a large number of fonts, as you can't hope to remember what more than a few fonts look like - it makes it easier to choose a font for a particular job if you have a printed guide available.

SHOWFONTs prints a single page printout for all fonts installed for ProForma. If you have 200 fonts installed, you can expect a 200 page printout, which could take a long time and quite a few paper tray changes if your printer does not have a large capacity tray. It will also make heavy demands on ink if you are using an inkjet or bubblejet printer.

DRIVERS - Prints out the names and ID numbers of printer drivers installed for ProForma. You need to know the driver ID number to use some of the programs.

Documentation is minimal, but adequate. Unfortunately, the manual I have contains a few errors which meant that in one or two cases, by following the instructions to the letter, the programs may not work. Here are a few examples:

(i) The program to add kerning information to fonts does not work quite as indicated in the manual. It requires a less than ('<') character to be placed before the filename passed as a parameter to the EX command which starts the program. Failure to include this means the program thinks no parameter has been passed. I only found out about this through trial and error.

(ii) Some of the programs can only be started with an EX command. If you try to use an EW command, nothing happens until basic stops with an ambiguous error report, which only gives a line number ("At line 0:").

(iii) The SHOWFONT program needs the font name (not the filename) to be typed in EXACTLY as it appears in the fontmap list. This means that the case of the name and the number of spaces etc has to match exactly. For example, if you have a font called Albatross, you must type in Albatross, not albatross or ALBATROSS. All that happens if you get it wrong is that nothing happens and the program asks you to enter another name. The manual does not warn of this pitfall.

Those little niggles apart, the manual is quite concise and to the point.

The conversion programs (PFB2PFF and ADDKERN) are command line driven, the font names being passed as parameters in an EX command, like this:

```
EX PFB2PFF;"<FLP1_PCFONT_PFB >FLP1_PCFO  
NT_PFF"
```

This is unfriendly, especially when you consider that pointer and menu driven programs such as LineDesign are quite friendly and easy to use on the whole. Given that you get the pointer environment and Menu Extension with Line Design, it appears silly that these conversion programs are not menu driven - they could have

simplified conversion by allowing the choice of filenames from a File Select menu, for example. That said, you only use the program once for each font converted, so once done the job is over; it is not a program you are going to use that often.

The first few fonts I converted by laboriously typing in such commands for each font, until I realised I could write a short basic program to do the conversion itself, effectively using basic as a batch file command. First of all I used Discover to copy the PC font files (all the .PFB and .AFM files) onto QL disks, ensuring that the filename extensions .PFB and .AFM are converted to _PFB

```

100 WDIR \ RAM1_TMP,FLP1_ _PFB
110 OPEN_IN #3,RAM1_TMP
120 REPEAT loop
130   IF EOF(#3) : EXIT loop
140   INPUT #3,f$
150   REMARK adapt '_PFB' to '_PFF' extension
160   t$ = f$ : t$(LEN(t$)) = 'F'
170   PRINT'Converting ';f$;' to ';t$;' ...'
180   EX FLP2_PFB2PFF;'<FLP1_'&f$&' >FLP1_'&t$
190   PAUSE 300
200 END REPEAT loop
210 CLOSE #3 : DELETE ram1_tmp
220 REMARK add kerning, where '_AFM' file exists
230 WDIR \ RAM1_TMP,FLP1_ _AFM
240 OPEN_IN #3,RAM1_TMP
250 REPEAT loop
260   IF EOF(#3) : EXIT loop
270   INPUT #3,f$
280   f$ = f$(1 to LEN(f$)-4) : REMARK remove extension
290   PRINT'Adding kerning information to ';f$
300   EX FLP2_ADDKERN;'<FLP1_'&f$
310   PAUSE 300
320 END REPEAT loop
330 CLOSE #3 : DELETE RAM1_TMP
340 PRINT'PROGRAM FINISHED.'
```

A couple of points to note: lines 100 and 230 contain a double underscore in the WDIR statement; there should be no spaces between the two characters. The PAUSE statements allow time for the executed program to finish before another copy is executed - some trial and error may be needed here to allow for the different speeds of operation of various QL configurations - I used 300 for Super Gold Card. Ensure that the disk used to convert the fonts (in FLP1_) is no more than half full or there will not be enough room to convert the fonts.

Having converted the fonts, the next step is to add them to the list in the PFfontmap file, so that they can be used by ProForma for Line Design and other applications. The PFconfig program

and _AFM respectively. The manual warns of one potential pitfall here - ProForma font names should not include underscore characters - ProForma tends to treat '_' characters as directory separators so you may find that FNT_BOLD_PFB ends up in the list as BOLD_PFB, the part before the first underscore having been treated as a directory name. It is a small matter to rename such fonts after conversion, before adding them to the fontmap. If any internal names embedded in the fonts cause errors, you can load the font into any editor capable of editing binary files and patch the names.

supplied with Line Design is used to do this. Just follow the instructions for PFconfig to do this.

The final step is to make printouts of the fonts, using the SHOWFONT program, after ensuring you know the driver ID number of the printer driver to be used. Execute the DRIVERS program to find this out. After starting the SHOWFONT program, you are asked to enter the destination (SER1 or PAR), the driver ID number (1 in my case) or nothing (no ID number) for a screen printout, which gives a rough guide of what the paper printout will look like. Then you need to type in the font name (note: not the filename). This is the internal name of the font as it appears in the fonts list in Line Design. Remember that the name must match exactly, including case. If you

get it wrong, the program just keeps asking for a font name without explaining what went wrong. The easiest way of making sure you know the names is to copy the fontmap file to a printer first, e.g. COPY_N PFontmap TO SER1. A menu drive choice of names, as in Line Design, would be much better here.

Given the very occasional use made of this software and the clearly limited application, I feel the program is overpriced for what it does, and for this price one would expect the software to be much more friendly. The software has the feel and unfriendliness of a package written for an author's own use, rather than for commercial release to other users. The errors in the manual require attention (it's possible that PROGS may have already attended to this as my manual is quite old, from DJC days). Having said all that, the program does the job, and the conversion process is quite quick, as is the neat font printouts.

I have used PFB2PFF to convert an 8 disk collection of fonts for use with Line Design (and other ProForma applications). The converted fonts have been placed with SJPD, Qubbesoft P/D and Quanta library and should be available from those sources once (if?) accepted.

PFB2PFF costs £66.00 from Q-Branch in England, or 3,000 Belgian Francs from PROGS in Belgium. ■

How to visit a QL Show

Duisburg, Germany - Jochen Merz

The following list is a rather tongue-in-cheek guideline for a visit to a QL show. Don't take it too seriously, as you'll see that some items are optional! In the early days I made the mistake of arriving at the shows just before they started and left as they finished. However, a QL show nowadays is much more than just the opening times of normally 10am to 5pm. It is often a social event too. If you have never been to a show, then you should visit the next one near you.

1. Prepare yourself for the journey - check road maps, trains, etc. to make sure you will not arrive too late. Being a bit late is okay, as this will allow traders who are sometimes late (like Miracle Systems and JMS!) a little extra time to set up their tables. Remember that countries like Britain have good car parks (they are called motorways).

2. Before you set off, make sure that you take all your software master disks with you, so that you can buy updates of your software while you're at

the show. Of course, it is a good idea to remember to take your cheque book or credit card with you for this...

3. It is always a good idea to bring your computer system to the show (unless it is a PC without a QL emulator, in which case it might get thrown out...), especially if you have software or hardware problems, as this enables the supplier to have a look at the problem in its real environment. You won't believe how many other users like to see other systems running and there is also a good chance that you can help others with their problems, or they can help you with your problems, and you will all feel good as a result.

4. Spend as much money as you can afford (preferably with JMS) - it's an investment in the future of the QL/QDOS/SMSQ... and in future shows, of course.

5. Once you're at the show time will run like mad. You'll wish there were 48 hours in a day! You won't notice how quickly time passes by while you're looking at other people's systems, follow speeches about new hardware and software, queue in front of Jochen Merz's table (because his disk drives are so slow copying disks), watch the TF Services robot complete the Tower of Hanoi puzzle, guess the length of Roy Wood's hair by now, etc. etc.

6. When the meeting is nearly over, don't rush off too quickly. JMS's disk drives might not have finished copying... No, seriously, there is often an organised (sometimes disorganised!!!) dinner in the evening which is guaranteed to be a lot of fun, especially if you try to eat more than Stuart Honeyball [Impossible - Dilwyn Jones]. It is sometimes fun to wait a little while after the end of the meeting, just to see Jochen Merz get thrown out, because he's usually one of the last to leave!

6.a) If the show is at Portsmouth, make sure your shoes are in good condition and eat something before you set off for the dinner, otherwise you may starve to death!

6.b) If the show is at Eindhoven, make sure you haven't eaten anything at all, because you can have as much good Chinese food as you want for less than £10.00 [unless you're slow, because Stuart will have eaten it all! - Dilwyn Jones]

6.c) If the show is in Britain, you have to take a coat, because it will almost certainly rain (the good old British weather!).

7. If you enjoyed the show, come along again next time. If you did not like it too much, tell the organiser why! ■

Q Branch

Feeling out on a limb?

Reach out for Q Branch

Suppliers of Quality QDOS / SMSQware

P.O. Box 7
Portslade
East Sussex
BN41 2ND

Tel. 01273-386030
Fax 01273-381577

UTILITIES.

FFI, The File Finder	£ 24.00
QPAC 1	£ 20.00
QPAC 2	£ 40.00
QSUP	£ 36.00
QTYP 2, Spelling Checker	£ 30.00
CueShell 2, File Utilities	£ 40.00
Disk Mate 5, File Utilities	£ 37.00
Q Spread, Spreadsheet	£ 77.00
Geoff Wicks' Style Checker	£ 15.00
Geoff Wicks' Solvit 2	£ 15.00
Geoff Wicks' Thesaurus	£ 15.00
QLerk, Archive accounts	£ 25.00
Printed manual for above	£ 20.00
DBEasy, Archive programs	£ 18.00
DBProgs, Archive programs	£ 14.00
DATAdesign database	£ 67.00
DATAdesign A.P.L.	£ 24.00
PFdata, printing from above)	£ 24.00
PFfontapack, fonts for LINEdesign	£ 89.00
PROforma,	£ 112.00

LINEdesign - The program that made this Ad :

£ 100.00

ARCADE GAMES

Arcanoids	£ 17.00
Firebirds	£ 17.00
Diamonds	£ 17.00
Doubleblock	£ 20.00
Super Games Pack	£ 40.00

POINTER ENVIRONMENT GAMES

Lonely Joker 2	£ 28.00
The Oracle	£ 24.00
QShang	£ 22.00
Bob's Pipes	£ 20.00
Mine Field	£ 19.00
Black Knight	£ 55.00
Brain Smasher	£ 20.00

PROGRAMMING.

QD 8	Text Editor	£ 58.00
QBasic		£ 23.00
QD+ Qbasic		£ 75.00
QD+ Qbasic + Qliberator		£ 120.00
Qliberator		£ 50.00
SPY	Text Editor	£ 15.00
Master SPY	Text Editor - enhanced version	£ 30.00
QPtr		£ 42.00
Easy Ptr	Ptr 1 - Base	£ 40.00
Easy Ptr	Ptr 2 - SuperBasic Interface	£ 20.00
EAsy Ptr	Ptr 3 - C Interface	£ 20.00
QMake		£ 21.00
QMenu		£ 20.00
QMon / JMon		£ 44.00
QLoad / QRef		£ 15.00
DISA 2		£ 40.00
IO Toolkit		£ 46.00
QDOS / SMSQ Reference Manual		£ 38.00
ProWesS	PROGS Windowing System	£ 50.00
SERmouse - Software and mouse		£ 40.00

SMSQ/E

For the Following systems:-

Gold or Super Gold Card	£ 90.00
QXL	£ 90.00

Atari

(Without QJump C.D.or E level Drivers)	£ 90.00
Including Drivers	£ 112.00
(The Atari programs above need a QVME Card to run)	
With Mono screen driver	£ 134.00

All three versions £ 180.00

With Mono screen driver £ 134.00

All three versions £ 180.00

Coming Soon : QPC! SMSQ/E on the PC!

For full details on the programs listed above
send a stamped addressed A5 envelope
to the address at the top of this ad.

We have many demo programs available - phone us and ask for details.

PC VERSUS QL

Bangor, Wales - Dilwyn Jones

The future of the QL is in your hands. The PCs are taking over. You must stop them at all costs. In this high speed action game you must prevent the PCs from invading the lands of the QL by using the cursor arrow keys to (very satisfying this!) squash the columns of advancing PCs rising from the bottom of the screen towards the top. Simply moving the black QL over the red PC columns and pushing them downward earns you points, shown at the top of the screen. You have 3 lives (3 QLs if you like) and your mission is to score as high as possible before the PCs finally take over.

I wrote this game because on several occasions recently I have nearly thrown my PC out of the window when it misbehaves [I too - Jochen].

PC versus QL is thus my revenge on the PC.

There is a choice of 10 difficulty levels, based on the speed at which the columns of PCs grow. As your score increases, the number of columns and the general speed of the game rises, so it gets more difficult as you get better. I have tried to ensure that the game runs reasonably well on all machine types running interpreted superBASIC, but inevitably the game will run faster on fast hardware such as Super Gold Card than on a Trump Card machine, for example. Just experiment a little by choosing a skill level suitable for you and your machine.

The overall speed can be changed by modifying lines 210 and 220, where the variable "limit_count" controls the number of user key scans per PC movement, so if limit_count=20, this means that the PC columns grow by 1 position roughly every 20 key scans. I have set this as a minimum of 10, since it becomes impossibly fast lower than this, but then, I'm not as young as I used to be...

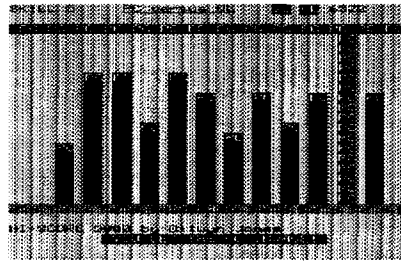
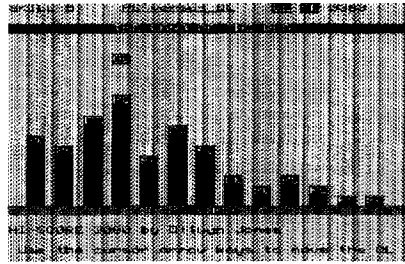

```
100 REMark PC versus QL by Dilwyn Jones
110 INITIALISE
120 skill = NEW_GAME : IF skill = -21 THEN STOP
130 NEXT_LIFE
140 REMark loop count slows the PCs down by expanding the PC columns
150 REMark only every 1 in limit_count passes of the loop
160 loop_count = 0 : REMark allows some degree of speed control
170 REPEAT game_loop
180 REMark the next line ensures that the game speeds up slightly
190 REMark as the score gets higher, and as the number of columns
200 REMark gets higher too.
210 limit_count = 10+((skill+1)*(lives+2))-INT(score/500)
220 IF limit_count < 10 : limit_count = 10
230 oldx = x : oldy = y : k$ = INKEY$
240 x = x + (k$=CHR$(200) AND x<13) - (k$=CHR$(192) AND x,1)
250 y = y + (k$=CHR$(216) AND y<19) - (k$=CHR$(208) AND y,3)
260 IF column(x) < y THEN
270   x = oldx : y = oldy
280 ELSE
290   IF column(x) = y THEN
300     REMark QL at top of column, so squashing a PC earns points
310     score = score + 20 - y + (9-skill) : column(x) = column(x) + 1
320     IF column(x) < 20 THEN
330       AT column(x),(3*x)-1 : PAPER 2 : INK 7
340       PRINT 'PC' : PAPER 6 : INK 0
350     END IF
360     AT 0,34 : PRINT score : BEEP 100,76-(4*y)
370   END IF
380   IF x <> oldx OR y <> oldy THEN
390     REMark QL has moved, so blank out old and show new position
400     AT oldy,(oldx * 3) - 1 : PAPER 6 : PRINT ' ' : AT y,(x * 3) - 1
410     PAPER 0 : INK 7 : PRINT'QL' : PAPER 6 : INK 0
420   END IF
430 END IF
440 columns = 2 + INT(score/300) : IF columns > 13 THEN columns = 13
450 number = RND(1 TO columns) : REMark choose a column to grow
460 REMark if QL is blocking it, column can't grow
```



```

470 IF x = number AND y = column(number)-1 THEN NEXT game_loop
480 REMark make the game start off more quickly and slow down later
490 loop_count = loop_count + 1
500 IF loop_count < limit_count THEN NEXT game_loop
510 loop_count = 0 : REMark reset it
520 IF column(number) < 20 THEN
530   AT column(number),(number*3)-1 : PAPER 2 : INK 7 : PRINT ' '
540 END IF
550 column(number) = column(number) - 1 : AT column(number),(number*3)-1
560 PAPER 2 : INK 7 : PRINT 'PC' : PAPER 6 : INK 0
570 REMark unless reached line 3, we have not been beaten yet
580 IF column(number) > 3 THEN NEXT game_loop
590 REMark oops, the PCs have overrun the QLS
600 AT 24,0 : PAPER 6 : CLS 3 : PAPER 2 : INK 7
610 FOR a=19 TO 2 STEP -1:AT a,(number * 3)-1:PRINT'PC':BEEP 100,95-5*a
620 AT 2,0 : CLS 3 : FLASH 1
630 PRINT' PC PC PC PC PC PC PC PC PC PC PC PC PC PC';
640 AT 23,10 : msg = RND(1 TO 5) : PAPER 3 : INK 7
650 SELEct ON msg
660   =1 : PRINT' OOPS, OH DEAR... !!!! '
670   =2 : PRINT' HOW CARELESS OF YOU! '
680   =3 : PRINT' YOU LET THE PC INVADE! '
690   =4 : PRINT' YOU LET THE QL DOWN! '
700   =5 : PRINT' THE PCS HAVE TAKEN OVER! '
710 END SELEct
720 AT y,(x*3)-1 : PAPER 2 : INK 7 : FLASH 1 : PRINT '**' : FLASH 0
730 FOR a = 1 TO 13 : column (a) = 20 : BEEP 100,70-5*a
740 AT y,(x*3)-1 : PAPER 6 : INK 0 : PRINT ' '
750 lives = lives - 1 : WAIT 3
760 REMark any lives left?
770 IF lives > 0 THEN NEXT_LIFE : NEXT game_loop
780 IF score <= hiscore THEN
790   skill = NEW_GAME : IF skill = -21 THEN EXIT game_loop
800   NEXT_LIFE : NEXT game_loop
810 END IF
820 REMark give a ranking based on score
830 AT 24,0 : PRINT'Your Ranking: ';
840 SELEct ON score
850   =0 TO 3000 : PRINT'More practise needed!';
860   =3001 TO 5000 : PRINT'Average...';
870   =5001 TO 10000 : PRINT'A true defender of the QL!';
880   =REMAINDER : PRINT'A knight of the land of QLS!';
890 END SELEct
900 WAIT 3: CLS: AT 2,6: PAPER 0: INK 5: PRINT' CONGRATULATIONS!!! ';
910 PAPER 6 : INK 1 : PRINT'\\TO 11;score;' beats ' ;
920 INK 0 : PRINT'\\TO 5;hiscore;' by ' ;name$
930 AT 15,8 : INPUT'Enter your name ' ;name$ : hiscore = score
940 skill = NEW_GAME : IF skill = -21 THEN EXIT game_loop : REMark ESC
950 NEXT_LIFE
960 END REPEAT game_loop
970 STOP
980 :
990 DEFine PROCedure INITIALISE
1000 MODE 8 : WINDOW 512,256,0,0 : PAPER 6 : INK 0 : CLS : CSIZE 2,0
1010 DIM column(13) : REMark column co-ordinates
1020 FOR a = 1 TO 13 : column(a) = 20
1030 hiscore = 3000 : name$ = 'Dilwyn Jones'
1040 END DEFine INITIALISE
1050 :
1060 DEFine FuNction NEW_GAME
1070 PAPER 6 : CLS : score = 0 : columns = 2 : lives = 3 : PAPER 1
1080 CSIZE 2,1 : INK 6 : AT 1,10 : PRINT' THE PC VERSUS THE QL '
1090 CSIZE 2,0 : PAPER 6 : INK 0 : PRINT '\\ TO 17;'NEW GAME'
1100 PRINT TO 16;FILL$('-',10)
1110 AT 10,4 : PRINT 'Skill level 0 (hard) - 9 (easy) ? ' ;
1120 REPEAT loop
1130   skl = CODE(INKEY$(-1))-48
1140   SELEct ON skl = -21,0 TO 9 : EXIT loop
1150 END REPEAT loop
1160 IF skl >= 0 THEN PRINT skl : ELSE PRINT'ESC'
1170 PAUSE 50 : RETurn skl
1180 END DEFine NEW_GAME

```

```

1190 :
1200 DEFine PROCedure NEXT_LIFE
1210 PAPER 6 : CLS : x = 5 : y = 3 : PRINT 'SKILL ';skill : AT 0,12
1220 INK 3 : UNDER 1 : PRINT'PC versus QL' : UNDER 0 : AT 0,28 : PAPER 6
1230 CLS 4 : AT 0,28 : PAPER 6 : CLS 4
1240 FOR a = 1 TO lives - 1
1250 PAPER 0 : INK 7 : PRINT'QL'; : PAPER 6 : PRINT ' ';
1260 END FOR a
1270 AT 2,11 : PAPER 1 : INK 7 : CLS 3 : PRINT 'THE LAND OF THE QLS'
1280 AT 20,17 : PAPER 2,0,3 : INK 7 : CLS 3
1290 PRINT 'PC LAND': PAPER 4 : INK 0 : AT 24,0 : CLS 3
1300 PRINT' Use the cursor arrow keys to move the QL ';
1310 PAPER 6 : AT 0,34 : PRINT score
1320 AT 22,0 : PRINT 'HI-SCORE ';hiscore;' by ';name$
1330 REMark deliver a replacement QL
1340 FOR a = 38*12 TO ((3*x)-1)*12 STEP -2
1350 CURSOR a,30 : PAPER 0 : INK 7 : PRINT'QL';
1360 PAPER 6 : PRINT ' '; : BEEP 100,20 : REMark PAUSE 1
1370 END FOR a
1380 PAPER 6 : INK 0
1390 END DEFine NEXT_LIFE
1400 :
1410 DEFine PROCedure WAIT (seconds)
1420 LOCAL time,loop
1430 REMark provides a fixed wait time, not interrupted by keypress
1440 time = DATE
1450 REPEAT loop : IF DATE>(time+seconds) THEN EXIT loop
1460 END DEFine WAIT

```

How we produce QL Today

The Editors

"The impossible we do at once, miracles take a bit longer." (note miracles, not Miracles!)

That quotation probably describes our efforts in producing issue 1 and 2 quite well. None of us has been a magazine editor before, and it turned out to be a greater logistical task than we'd imagined. As traders (or ex-trader in Dilwyn's case) we thought we knew all there was to know about deadlines, problems, and technical hitches. Wrong... This article takes a light hearted look at how we achieve the near-impossible every two months.

The magazine is produced on a variety of computers, including QLs, Atari STs, PCs and QXLs. By far the most troublesome machine so far has been Dilwyn's PC, which has nearly been thrown out of the window many times. This is true for Jochen's PC too!

Articles arrive on disk in most cases (shorter articles and news often in printed or faxed form for retyping). Files arrive in a random selection of Text 87, Perfection, Quill/Exchange or plain text files and get stuffed through a variety of conversion programs to try to end up with what we want. Screen dumps get manipulated in ways you never thought possible and usually placed in a part of the article the author never intended (so far we haven't actually managed to put any pictures upside down!).

Jochen gets any photographs scanned where this is preferable to pasting in the original picture. No tubes of glue involved here (just a GLUE chip in the QXL and the ATARIs).

Once we have something which we think we can use, articles are passed between the three of us by modem for checking, editing, rejection, etc. It's usually at this stage that Dilwyn's PC decides that this issue is not going to go out on time, because the modem decides it doesn't want to play at editing magazines.

Having learned a few new Welsh and German impolite words, it is finally persuaded to co-operate, its role gets reduced as much as possible (its fast modem is the only reason it gets used at all) to teach it a lesson, and it is usually given a final warning about its conduct and moved a little nearer to the window to intimidate the poor thing...

Eventually, decisions are made, files fly backwards and forwards and the magazine content agreed (difficult this decision-making by committee when the three of us are so far apart!). Usually at this point, Jochen's hard disk crashes or some other equally unfortunate incident occurs, or Jochen gets flooded with orders for a new product [ha, ha! - more likely, the car breaks down!] and has no time left for anything. In this case, he gives up and goes on one of his six holidays per year... (only joking!)

Meanwhile, the lone Englishman (Stuart) sits back and has a good laugh at the expense of everyone else. But as the only 'real' Englishman,

he gets the job of checking the English in the magazine, while Jochen checks the German content, and then we all have a good laugh when Stuart gets it wrong.

By now, it's the 15th of the month, and panic has set in because some articles are late, changes have to be made and vast quantities of tranquilisers are ordered...

But, like the cool customer he is, Jochen keeps going, often well into the night. Joking apart, it can take several hours to prepare some articles. Provided Dilwyn and Stuart did a reasonable job in preparing the articles, Jochen and his trusty ST start to lay out the contents in preparation for printing out the masters. Some parts of the magazine are similar each month, which reduces the work a little. Because some articles tend to arrive late (like the magazine editorial column), Jochen has to guess how much space to leave for certain parts and get on with what he can, making small adjustments later. The magazine is finally prepared and printed on Calamus, an Atari DTP program.

Finally, he takes it out to be printed, and this can take several days. The number of copies printed will vary, depending on the subscription base at the time.

Now comes a tricky bit. In order to keep costs down, Jochen and Stuart have looked carefully at how much it costs to send issues to various countries from Britain, Germany and The Netherlands. So issues to some countries will arrive bearing British stamps, while others will arrive with Dutch or German stamps. Dilwyn is not involved by now or we may even have some stamps with Welsh dragons on them to complicate matters (anyway, his PC may have caused absolute chaos!) A great deal of care and thought goes into this to try to ensure everyone gets their issues at roughly the same time.

So there you have it. QL Today is produced by three QL enthusiasts for all QL enthusiasts. A bit of luck and a lot of hard work brings you a copy of QL Today every other month. ■

Rectification

Jonathan Hudson wrote:

In the recent edition of 'QL Today' (well done all concerned), Jochen states that the industry standard file transfer protocol ZMODEM, and particularly its implementation in QTPI, is 'silly'. A little thought might demonstrate that it is the unusual behaviour of the SMSQ/E operating system that is causing the problem.

ZMODEM attempts to transmit data as fast as possible to the remote system. When it has sent all the data, it waits for a fixed time for an acknowledgement from the remote. If this acknowledgement is not received in the time, then a failure occurs.

It appears that the SMSQ/E operating systems report that the transfer has completed even though there may still be large amounts of data remaining in the serial buffers which has *not* been transmitted. Sorry, Jochen, but if your operating system chooses to mislead the application, that's your problem. Of the multitude of operating systems that support ZMODEM, yours is the only one that *defaults* to such strange behaviour -- perhaps you should fix it.

The superHermes method of allocating buffers on a per-usage basis is a much more flexible approach.

For example, the SMSQ/E 'serd' (direct option) might also dispense with the buffering because this is counter-productive to robust communications, particularly those that depend on predictable timings. Such buffers are fine for sending to printers, but counter-productive for comms. A more constructive (and less pejorative?) approach might then encourage software authors to support additional features (like ser3/4, d option etc) in newer operating systems, particularly if the authors are made aware of what is required.

Jochen's reply:

Dear Jonathan, I am sorry about the wording. You can see that English is not my first language. The "silly" was definitely not meant to describe the implementation of QTPI (in fact, I think that both QTPI and QFAX are excellent programs, and I tell other people so).

SMSQ/E allows dynamic buffering as well as fixed buffering - it is up to the user. SERD with buffering is very useful to me, as it allows me to send a lot of text87 (and LineDesign) output to a SER or PAR channel, buffered, but without the translation. "d" has nothing to do with the buffering, and making "d" automatically not using the buffers would restrict the general usage. There is nothing which prevents you from using the "d" parameter together with small or no buffers.

It is up to the user to define if he wants the buffering or if he does not want it. For printing output, the buffering is very useful, for communications it is not useful, I agree (and this is why I told people to limit the buffers).

However, if the transmission would run over a digital line or directly between two computers and there are no transmission errors, then buffering the transmitted data could work. But this would mean that it would start counting its timeout as described, i.e. take the baud rate into account if it is obvious that the data could not really go at the

speed it was gone. It was more a theoretical explanation, and I would not expect Jonathan to change his QTPI in such a way (especially AS we are not living in a perfect world with perfect communications - I mean the physical connection services!).

Anyway, to come to a conclusion: the idea of the small article was definitely NOT to blame Jonathan's QTPI but to explain why the buffers have to be set to a fixed small size. ■

QDESIGN fix

Jochen Merz

If you own QDesign and you find that it does not run on ATARI Mega STE, TT (and maybe some other machines), here is how this problem can be overcome: I have tested QDesign V3.12 and V4.04, and the way it checks for "non-QL" machines is wrong on both versions, so I guess it will be the same fault on other versions too. As the offending code is located at different positions in the different versions, there is no general way to do it automatically. It helps having a debugger like QMON or JMON. If you don't know how to use it, then maybe you can find somebody on a local usergroup meeting who could do it for you.

Here is how you do it: QDesign checks for non-QL systems by using the following code:

```
MOVE SR,D0
TRAP #0 ; Into supervisor mode
MOVE.W D0,-(A7) ; save status register
LEA $FC0000,A0
; the base of old ATARI ROMs
CMPM.L (A0)+,(A1)+
; and here goes QMON/JMON ... BANG!!!
BNE.S ...
```

The ROM was located at address \$FC0000 onwards only on the old ATARI models, now it starts at \$E00000 because the ROM size grew and more address space was required. Accessing this address in a TT or Mega STE will generate a bus error! If you find this place in the code, you just replace the first instruction with `CMPL A0,A0` (to set the Z flag) and RTS - forget about the rest. This way QDesign always thinks it is running on an ATARI. If you want to do it properly, read the machine system variable (but you will not notice a difference in QDesign anyway).

The address to look at in V3.12 is \$121C4, in V4.04 it is \$149B0. Maybe we can collect the addresses of other versions and write a short patch program which will deal with all known versions?

■

Disk Drive News & Comment

Bangor, Wales - Dilwyn Jones

QL Today has been informed of possible problems facing QL users who attempt to construct dual disk drive systems using new 1.4MB drives. It seems that in order to reduce costs, some manufacturers no longer produce drives which have the drive select jumper position to allow selection of drive numbers. This is largely a result of what is happening in the PC world, where it is now unusual to find machines with more than one floppy drive. Drive board modifications can get around this problem, but in the short term the solution for QL owners is to ask the suppliers if their drives have the drive select jumper, since there are still plenty of older drives around.

It is now becoming increasingly difficult to obtain supplies of the ED drives (3.2MB on the QL), as TEAC have discontinued supply, and only limited supplies are available from Mitsubishi. Thankfully, the ED disks themselves are not in such short supply, as stocks are still available from both SJPD and W. N. Richardson & Co.

Again, it seems likely that this drive shortage is a result of what is happening on the PC scene, where the 2.8MB drives (the capacity when used on a PC) failed to gain universal acceptance, and also as a result of the move towards 'super floppies' of 100MB or higher capacity such as the Iomega Zip and Syquest systems. These drives can be accessed to some extent by QDOS and SMSQ users - QXL users can access a Zip drive on a PC's parallel port by formatting the 100MB disks to contain the usual QXL.win file, and Qubide users can use the 135MB disks of the Syquest EZ-drive systems, available from Qubbesoft P/D, who also plan to make software available on these disks and have come to a special arrangement with Quanta to be able to supply the entire Quanta library on a disk (for Quanta members only of course). What is now required of course is for drivers for these large capacity super floppies to become available for QDOS users to be able to use them on their machines. Some of the super floppy drives can be connected via a standard bi-directional parallel port, so if new hardware available (e.g. the Aurora) were to include such a port, in time drivers may become available to allow use of these systems on the QL.

■

Im stillen Winkel 12 • 47169 Duisburg • Germany
 ☎ 0203-502011 (Fax 0203-502012 Mailbox 0203-502013 & 502014)

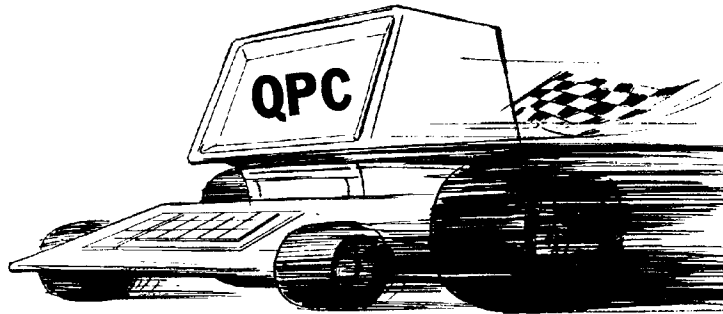

QPC is coming!

QPC, the brandnew QL-Software-Emulator running SMSQ/E is ready very soon (we expect end of July). You can run SMSQ/E now on PC's and even Laptops without extra emulator hardware! Minimum requirement: 486 or Pentium. Price: DM 199,- for customers who already own SMSQ/E for other systems, otherwise it will be DM 249,-.

SMSQ/E V2.75

SMSQ/E - the great QDOS-compatible operating system with lots of new features is available for all ATARI ST, STE and TT computers, for any QL with GOLDCard or SuperGOLDCard, and for the QXL. The manual is now Revision 6 - including the SERNET documentation and all the changes so far. A new manual costs **DM 16,-**.

	Feature	ATARI ST(E)/TT	(Super)GoldCard	QXL
This exists NOW!	New Operating System	NEW DM 199,-	NEW	already ex.
	Multiple, fast BASICs	NEW (if you own the QJUMP-drivers Level C, D or E already) else	NEW DM 199,-	already ex. DM 199,-
	Flexible Level 3 Drivers	NEW	NEW	already ex.
	HD Disk-drive support (STE/TT)	NEW DM 249,-	already ex.	already ex.
	TT Fast RAM support	NEW	impossible	impossible
	Monochrome Screen-driver	NEW + DM 50,-	impossible	impossible
Later..	New Screen-driver	NEW + DM 50,-	NEW + DM 50,-	NEW + DM 50,-
	"background" Disk/Harddisk	NEW + DM 50,-	impossible	NEW + DM 50,-
	BASIC-Development-Environment	NEW + DM 50,-	NEW + DM 50,-	NEW + DM 50,-
	Total price (when all is available)	with rebate, without DM 349,-	DM 299,-	DM 349,-

As a special bonus (we know that many users own more than one system), we offer the version of an additional system 33% more. This also applies to the upgrades, e.g. DM 66,66 instead of DM 50,-, which, we think is very fair (it just covers extra disks and manuals).

Call or write for more information about the products listed above and our complete software range!

TERMS OF PAYMENT

Postage and package (Europe) DM 14,- (if total value of goods is up to DM 50,- then only DM 9,-). (Overseas) between DM 14,- (1 item) and DM 35,- (maximum). All prices incl. 15% V.A.T. (can be deducted for orders from non-EEC-countries). E&OE. Cheques in DM, £'s, Eurocheques and Credit Cards accepted.

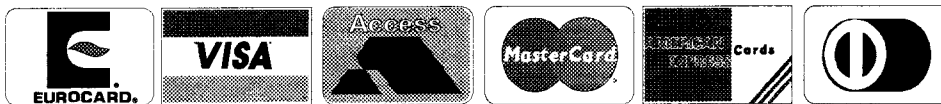
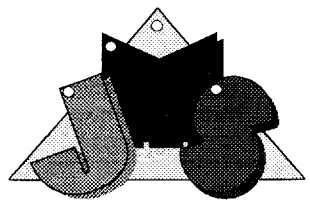

Speedup your QXL

Northampton, England - Terry Harman

Disclaimer: Whatever you do to your QXL, you do it at your own risk! Modifying your QXL card may lead to a loss of warranty!

I am now running my QXL at 32 Mhz (64 Mhz crystal) instead of the standard 20 Mhz (40 Mhz crystal), it now runs at just under TWICE the original speed for a total outlay of Eight Pounds Twenty Nine pence!!

£3.27.....64 Mhz crystal from Maplin Code CW93B Type 64 Mhz Oscillator £5.00.....586 CPU heatsink and fan from Ram Computers in Bristol (or endless other PC bits suppliers).

Fitting is simple. Remove the crystal from its socket next to the glue. Note the * is the position of the dot on the crystal package. Plug in the new crystal, dot where the star is in diag. They are a different package size, so the * moves from middle left to top left.

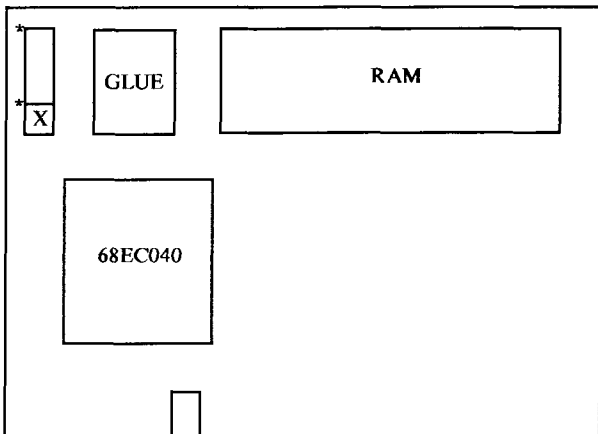

Smear a small amount of heat transfer compound onto the top of the 68040 and the bottom of the heatsink. Fit the heatsink onto the 68EC040 with the clips provided (it fits a treat). Connect the fan power supply with the adaptor supplied.

Now for the sneaky bit!! The heatsink 68EC040 doesn't need the fan but the glue does. The heatsink fan is attached with 4 screws ... 1 on each corner. Move the fan so it is blowing onto the glue.

Good quality fresh heat transfer compound is important!! Guess who spent 3 days wondering why his go faster QXL kept

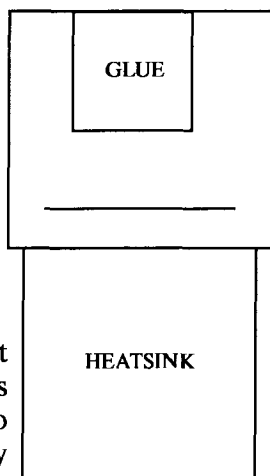

stopping after 2 or 3 hours? The same bloke who had to dig his 4 year old compound out of the tube, because something that solid wouldn't squeeze out as it should!! 50 pence well spent.

What made me think of doing it? The truth is that I was bored, so was flicking through the Maplin catalog and noticed the 64Mhz crystal (that is so SAD.) Their shop's about 20 minutes away so I thought it's only £3.27; it almost certainly won't work, but it will give me an afternoons amusement. (the lengths some people will go to! -editor)

The only technical preparation I did was to check that the larger package size crystals were accomadated on the QXL board. No Problem, Miracle have wired the socket so that both will work.

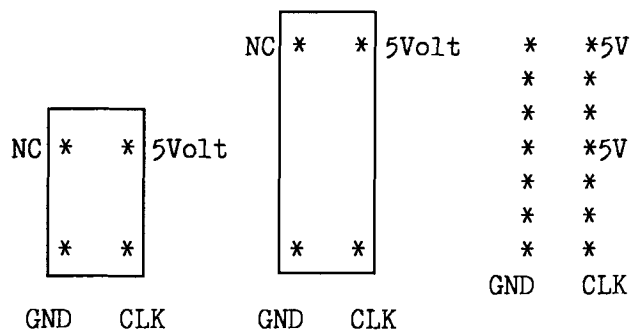

The heatsink and fan I was going to do anyway. The Std 20Mhz 68EC040 gets hot. This is normal and is not a problem. If you crank the speed up, you generate more heat in the chip which causes the thing to shut down. With the heatsink, the chip is running a lot cooler even when cranked up.

NO HEATSINKEEE .. NO WORKEEE ... FOR LONGEE

Will it work for you? My QXL is eighteen months old with the standard speed GLUE (25ns), RAM (70ns) and 68EC040 (20Mhz). I have had it since new and it has not been modified in any way apart from the crystal and heatsink/fan.

That's shot down the can't work ... won't work unless you spend £400 brigade!! I don't know if this mod will work on a 286 or 386 PC, simply because I don't have access to these types of PC's to try it.

There may be a limitation regarding the speed of the PC processor, and/or the speed of the PC's BUS ... I don't know. Clearly if there is a limitation it is NOT the QXL card, so why not do what I did and lash out £3.29 to try it.

20 Feb 1996 The Fastest QXL this side of the PECOS

80 Mhz MAN HAS ARRIVED

Did I write that?..It must have been that beer last night. I can't quite remember what the celebration was for ... something like sinkpound...

This was slightly more involved, it needed a heatsink on the glue to be reliable...it started playing up under load without one.

I made a nice finned alloy heatsink by cutting up an old QL one, and trimmed the height so that the fan held it in place.

I did of course put a smear of heat transfer compound (sigh!!) in the appropriate place.

RESULTS

I have tried the following QXL crystal speeds.

PC	Bus Speed	QXL Crystal	Speedup
		40Mhz	0% Standard QXL
486 DX4 100Mhz	33Mhz	55Mhz	40%
486 DX4 100Mhz	33Mhz	64Mhz	90% nearly 2 x faster
486 DX4 100Mhz	33Mhz	80Mhz	150% 2 1/2 x faster

The tests were done under both dos and windows; SMSQ AND SMSQ/E at 800 x 600 resolution running a benchmark program in a continuous loop for at least 8 hours.

This ensured the QXL was running flat out..or for the more technically aware "gave it a right good thrashing lad!! "

Read this and weep non QXLers..(who said that?!!!)

	40MhzQXL	32MhzQXL	20MhzQXL	16MhzATARI	16MhzGOLDCARD
bench1	1	1	1	5	5
bench2	0	0	1	3	4
bench3	3	3	6	24	21
bench4	2	3	5	22	21
bench5	2	3	5	22	21
bench6	1	1	3	10	10
bench7	8	11	20	80	77
bench8	2	3	5	19	23
bench9	1	1	2	8	7
bench10	1	0	1	3	6
bench11	2	3	6	27	22
bench12	2	2	4	19	30
bench13	1	1	2	6	6
bench14	6	7	13	42	62
bench15	11	14	28	149	198
total	43	53	102	439	513

time in seconds The Benchmark programs are @ DJS GUTHRIE 13/10/84 @

All I did was to bolt them all together, and increase the work each benchmark had to do (they finnished too quickly else). They do give a fair comparison of processing speed and screen/graphics speed between machines, the Standard QXL does feel and look 5 times faster than the GC.

Floppy load/save etc is now up to normal speed (about 15k bytes a second). Hard disc load/save has improved considerably. Xchange takes 3 secs to load instead of 6, still relatively slow for a hard disc, but good enough (for now). Saving/copying to hard

disc is up to normal hard disc speed. Screen update is excellent. It's now sharp and fast, particulally noticable when you scroll large amounts of text etc.

Serial ports work as usual. I run a mouse off com1, and a 14400 fax modem card off com2 (ser2) I use QTPI with ZMODEM and get around 1600 char/sec upload and download. The Mouse is very good, was slightly sluggish before.

The only fly in the ointment is the network doesn't work with a QL. There is no reason why QXL's with the same faster crystal won't network with each other, though this hasn't been tested yet.

I occasionally need to network my QXL to a QL, so have made a 2 crystal adaptor board so I can switch back to 20Mhz if needed.

It runs Cool, Smooth, Reliable and Fast. It improves the QXL's weaker points dramatically. It is also extremely cheap and easy to do... I should have done this ages ago!!

FINALLY FOR NOW

I don't know how fast the QXL will go. My usual method is to crank the thing up until it starts to get flakey, see if there is a cheap fix, if so.. carry on, if not..back off a bit and stop.

(ignore the shrieks from the back of the hall, the purists are going into spasms now.....bless them!!)

Eventually you hit a barrier that needs lots of money throwing at it to get past. You can sometimes see it coming as the performance increases get smaller and smaller, sometimes you just hit it.

Unfortunately I haven't been able to find any 90Mhz or over crystals. I am going to knock up a clock generator 90/100Mhz and see what happens. If it doesn't work I'll know I've hit the low cost barrier.

If it does work at 90 or 100 Mhz, I seem to recall that some of our American colleagues got their hands on some 33Mhz 68EC040's (oohh, lovely!)

The 33Mhz run a lot cooler than the 20 Mhz ones, and with a 100Mhz crystal would only be overclocked by a half. If it's 81MHz or 120MHz it's going to be fun finding out.

Disclaimer: Whatever you do to your QXL, you do it at your own risk! Modifying your QXL card may lead to a loss of warranty! ■

QL Service List - Part 1

Preface

Dear reader,

this is the third edition of the service list for the Sinclair QL computer. The hypertext version of this list is much easier to handle than the second edition.

Due to historical reasons the entries aren't ordered very well. Sometimes the first name of a person has been taken as the sorting field, sometimes the second name. Furthermore some of the vendors may be in the wrong section (e.g. in the hardware part instead of the software part). You've been warned!

If there's someone out there who is willing to help me converting telephone numbers from national to international format please contact me.

Telephone numbers are in international or local format. I still don't know how to convert local numbers to international format. ATTENTION: The phone numbers have changed in the UK. Older numbers will not be correct anymore.

If you are looking for a list that covers the availability of QL resources on the internet more, please have a look at the QL Internet Resource list from Richard Zidlicky. It is posted regularly to the newsgroups comp.sys.sinclair and maus.sys.ql.int.

This Service list as well as the QL FAQ is available via World Wide Web at

<http://www.uni-mainz.de/~roklein/ql>

Notes: Only larger dealers have Fax, often on the same number. Some numbers no longer active in the QL world are give for reference and support queries.

If you have any ideas, suggestions, criticism please mail me at

RoKlein@Goofy.ZDV.Uni-Mainz.DE.

Well, now relax and enjoy.

Robert Klein

NEWS

IQLR has closed with vol5 iss6 (i.e. march 1996) due to a serious illness of its editor, Bob Dyl sr.

A new magazine will take its place, QL Today. It is published by Jochen Merz Software, Germany in cooperation with Miracle Systems Limited, UK and edited by Dilwyn Jones, UK. Watch comp.sys.sinclair and your snail mailbox for further information. Addresses in the magazine part.

QL world has closed with volume 3 issue 5 (i.e. may 1994). If you think you have a claim concerning undelivered subscriptions, write to Arcwind at the following address:

Arcwind Ltd
The Blue Barn,
Tew Lane Wootton,
Woodstock Oxon.
OX7 1HA
Great Britain

Warranty information

In no circumstances will the maintainer of this list be liable for any direct, indirect, incidental or consequential damage or loss including but not limited to loss of use, stored data, profit or contracts which may arise from any error, defect or failure of the QL Service List or the information supplied with it.

The list maintainer has a policy of constant development and improvement of this list. Therefore, the right is reserved to change the lists contents at any time and without notice.

Each part of this list may be reproduced in any form whatsoever without the written permission of the list maintainer.

How to submit new material to the Service List:

Just drop me a mail at

RoKlein@Goofy.ZDV.Uni-Mainz.DE.

The Subject should at least contain the term QL.

Hardware dealers

Care Electronics

01923 / 672 102

- Tebby connection but no longer dealing directly

CL Systems

0181 / 459 1351

- Real Time Digitizer

Computer Technik (Jürgen Falkenberg)

Parkstraße 25

D-75223 Niefern-Öschelbronn

phone/fax: +49 - 7233 / 81515 (Germany)

- Hard disk interface/systems, tower housings for QL systems.

Dilwyn Jones Computing

41 Bro Emrys

Tal-y-Bont

Bangor

Gwynedd, LL57 3YT

(Great Britain)

phone/fax: +44 - 1248 / 354 023

- Process controller, power regulator, network prover. (closed in March 95)

Ing. Büro Michael Klein

Martinstrasse 23

D-64285 Darmstadt

Germany

- QL compatible computer (Primus).

Miracle Systems Limited

20 Mow Barton

Yate

Bristol, BS17 5NF

(United Kingdom)

phone/fax +44 - 1454 / 883 602

- (Super) Gold Card expansion card; QXL PC card; disk adaptor; Centronics adaptor/lead; QXL Gold (S)GC-ISA Bridge.

Qubbesoft PD

38 Brunwin Road, Rayne, Braintree

Essex CM7 5BU

(Great Britain)

phone: +44 - 1376 / 347 852

fax : +44 - 1376 / 331 267

email: 101634.776@compuserve.com

- Miracle Trump Card, Expanderam, twin 3.5" disk drives. Sales and support. Qubide QL AT/IDE hard disk interface. QL Mini Tower Kit. 2nd user QL hardware and software. QPlane. AT/IDE hard disk drives. Soon: Aurora Graphics Card (QL motherboard replacement)

W N Richardson (EEC Ltd.)

6 Ravensmead

Chalfont-St.-Peter

Buckinghamshire, SL9 0NB

(United Kingdom)

phone/fax: +44 - 1494 / 871 319

car phone: 0850 / 597 650

- Complete QL systems, monitors, keyboards and interfaces, disk drives and printers, peripherals, Z88.

TF Services

Holly Corner, Priory Road

ASCOT, Berks, SL5 8RL

(United Kingdom)

phone: +44 - 1344 / 890 986

Fax: +44 - 1344 / 890 987

email: tony@firshman.demon.co.uk

- Hermes IPC, Minerva ROM, keyboard membrane, repairs, spares, superHermes etc.

Services

Adman Services (Dennis Briggs)

01952 / 255 895

- Spares, repairs, support, peripherals.

Joe Atkinson

36 Ranelagh RD, London W5 5RJ

- Roms, mdvs, spares, PD software.

For QL products in the U.S., contact:
FWD computing (former Mechanical Affinity)
P.O. Box 17
Mexico, IN 46958
USA
(317) 473 - 8031 Tuesday thru Saturday only, 6 to 9 pm
fax: (317) 472 - 0783 7 pm thru 11 am
email: fdavis@walnut.holli.com
- Hardware, software, services, repair etc. Main US hardware and software supplier.

Suredata
0181 / 902 5218
- Repairs

QL World (Readers' Services)
01993 / 811 181 (Ask for Fran)
- Subscriptions, binders, recent backissues.

Quanta
General Secretary: John Mason
73, Chewton Common Rd
Highcliffe, Christchurch, Dorset
BH23 5LZ
01425 / 275 894
- User group, support, library.

Quanta
Membership Secretary: Bill Newell
213 Manor Road
Benfleet, Essex
SS7 4JD
01268 / 754 407

Will be continued in the next issue of QL Today!



GO

Duisburg, Germany - Jochen Merz

This game is a conversion of a GnuGo, done by Jerome Grimbert.

If you haven't heard about a game called "Go" yet then this article might not be too interesting for you, as it doesn't teach you how to play Go. However, if you think it sounds interesting, then you should go to your library or bookstore and get a book which explains how to play "Go". It is a strategy game, not similar to Chess or anything else you've played before. There aren't very many rules, but the way you put your stones has to be learned. There are various basic figures which can be modified in many, many ways, and every game is different.

But now to the implementation: The Go I'm talking about runs under the Pointer Environment, and it's PD! You can start with handicap stones, so if you think it is too easy choose a higher handicap.

I have to say that it took me three games to win one (see the screenshot). The machine seems to play harder during the first half of the game, also it made some very mean moves. I like it!

A game of Go usually takes a while, so you can save the current part and continue later.

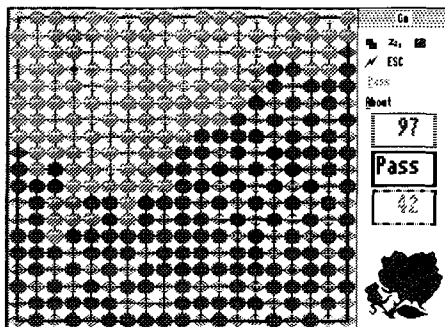

It's useful to have a fast machine, otherwise the computer will think a short while. On my TT, it reacted within 5 to 6 seconds at most.

You can find Go (it's called Goban, don't know why!) in my QDOS-Box 2, where

you can download it yourself. Jerome does not want any charge on copying media etc., so I cannot ship it to you using my cheap PD service. If you cannot get it through BBs's, then you'd better write to Jerome directly.

I can definitely say: Go is a great game, and thanks, Jerome, for porting it! I enjoyed these three games, and I'm pretty sure I'll play some more when I find the time. ■

PIP in progress

London, England - Mark Knight

I am in the process of writing a program to output Perfection document files to a printer with better presentation than Perfection can manage with its internal printer driver. The program will be called PIP, short for Perfection In Print. I intend to support proportional spacing, in-paragraph space correction, microspacing or micro-justification, proper kerning and suppression of widows and orphans.

For those who don't know, a widow is an odd single line from a paragraph at the end of a page, while an orphan is a single line at the start spilling over from a previous page (I think it's that way around). Some advanced (and expensive) word-processors will automatically prevent this and I decided I wanted my documents presented this way too. The user will be able to set the program to give a minimum of two or three lines at the start or end, and if a paragraph cannot be printed on the current page or over a page boundary without

PROGS

Professional & Graphical Software

Haachtstraat 92, 3020 Veltem, Belgium, tel/fax : +32-16/ 48 89 52

ProWesS *pre-release version*
available now

After more than a eighteen months work, we are very proud that we can announce our new product, which we believe will be an important new environment for the QL.

ProWesS is the "PROGS Window Manager". It contains the complete environment for running ProWesS applications. This is currently the pre-release version. We do not consider the package to be finished just yet, however, especially the ProWesS reader which is part of the package may be interesting to many users, and we would like to get comments about the system as soon as possible.

The ProWesS reader is a major part of the package. It is a hypertext document browser. This means that text files which include formatting commands and possibly links to other files can be displayed and read in this program. This is used in ProWesS to read (and possibly print) the manuals, and display the help files. The hypertext documents which are used by the ProWesS reader are in HTML format, the format which is popular on Internet to display World Wide Web pages.

All registered ProWesS users will get a free update to ProWesS when the full version is available. The package currently contains (apart from the libraries) the ProWesS reader, which allows you to browse hypertext documents (in HTML format), the ProWesS loader, which allows loading applications, including all the required extensions without reset, and some small sample applications (like a calculator). Many more utilities and installation software will be sent to you as the free upgrade to the full version !

ProWesS does not include the programming documentation. This is available via bulletin board and public domain software suppliers. The programming documentation is readable in the ProWesS reader, and partly in DATAdesign (the demo version is be included).

order your copy of ProWesS today ! for only BEF 2400

Payment terms :

ProWesS is available NOW for BEF 2400 (HD, excluding postage). It is normally distributed on high density (HD) disks. However it can be obtained on double density (DD) disks at an extra costs of BEF 100.

If you are VAT registered (specify registration number) or live outside the EEC, the amount to be paid is the total (including postage) divided by 1.21 (no need to pay too much).

Payment can be done by EuroCheque in BEF, or by VISA, EuroCard or MasterCard. Credit card orders can be handled by phone. For credit card, please specify name of card owner, card number and expiry date.

Postage : Costs of postage and packaging have to be added. You can choose the quality. Rate depends on no of programs.

copies	priority mail			ordinary mail		
	Belgium	Europe	World	Belgium	Europe	World
one	100	200	230	100	120	135
two	110	340	420	110	180	215
3 or 4	120	560	770	120	300	370
5 to 3	160	870	1250	160	550	675
more	200	1130	1610	200	800	1005

All prices are in BEF, including 21% VAT

the minimum number of lines present on each page the whole paragraph will be printed on the next page.

PIP will support printing to an accuracy of 2400 Dots-Per-Inch (DPI) for A4 or letter paper, 1200 DPI for A3 and 600 DPI for A2. This should make it future proof since even glossy magazines don't exceed 2400 DPI and QL users are hardly likely to own a printer this capable. Microjustification will use these resolutions if the printer can cope, a minimum capability of 120 DPI positioning is required from your printer to use the program. Almost every printer sold since the QL was first produced can manage 120 DPI or better so if you are not familiar with these matters don't worry; PIP will drive your printer to perform the above listed miracles unless it is very primitive indeed. Daisywheel printers almost all allow character positioning to 120th of an inch so if you own one of these don't worry, just buy some earplugs if you can't afford a more modern printer. Whatever your printer Perfection used with PIP will be able to get the best out of it in typographic terms.

If you like the sound of this let me know; PIP is going to take months to finish in between all my hospital trips and I could do with something to help me keep going. The most difficult job is not PIP itself but the program designed to allow PIP printer drivers to be edited. As the driver supports up to 35 fonts the editor must allow the setup of up to 35 width tables, 35 translate tables, 35 kerning tables, up to a total of 1024 translates, a set of comprehensive control codes and various other features. PIP can only use 8 fonts in a document but other software I write may be able to use more of the driver's features. ■

Small ads

As *QL Today* will become one of the most important sources for QL news, nearly all QL dealers advertise in here. This brought up the question why only QL dealers should be allowed, why not QL users who would like to buy and/or sell their programs, hardware, developments - whatever they think might interest other QL users. In the beginning, people could have marketed their software via clubs, like the German User Club. Why not make it possible for them to do it themselves? There will be no difference in price between private ads and commercial ads: up to 50 words cost DM 5,- (or 3 IRC's), up to 100 words DM 10,- (or 6 IRC's).

SERNET

Duisburg, Germany - Jochen Merz

You probably guessed from the name that SERNET is a network driver which works over the serial port. You're right!

SERNET is based on Phil Borman's excellent MIDINET driver, which was modified by Bernd Reinhardt so that it uses the serial port instead of the MIDI port. As all machines connected to SERNET have to form a ring (like MIDINET, where MIDI OUT goes to the MIDI IN of the next machine), you can either connect two machines with a standard serial cable or more than two machines with special cables, where the output signals of machine 1 have to go to the input signals of machine 2, the output signals of machine 2 have to go to the input signals of machine 3 and so on.

SERNET will work on SMSQ/E only, as this is the only system which supports independent channels for SER transmission (STX) and SER reception (SRX). The good news is that you can now connect QLs and QXLs and ATARIs together, all running SMSQ/E! Of course, all serial ports have to run at the same baudrate. SERNET will support any possible baudrate, so if you connect two modern ATARIs together, you can go up to 250,000 Baud!

SERNET will work in the same way as midinet. You can configure the driver name to be "N" or "S" or any other character you like, so it can easily replace the TK2-Network or MIDINET without any change in your software.

If you ran MIDINET before you will not only benefit from much higher possible baudrates, but also the machine initiating the network communications will still react, unlike MIDINET. This is mainly due to the fact that MIDI has no handshake, so it has to make sure that no characters are lost during network transmission. As SERNET runs with handshake enabled, no characters can get lost.

And now the really good news: SERNET will come free with SMSQ/E! SMSQ/E's manual is now Revision 6, explaining all the new commands and features. If you're used to MIDINET, you don't even need a new manual (if you already have Revision 5), because SERNET works in a very similar way. Otherwise, an update manual costs DM 16,-. ■

QUANTA

SUPER GOLD CARD

"The Pathway to Future QL Development"

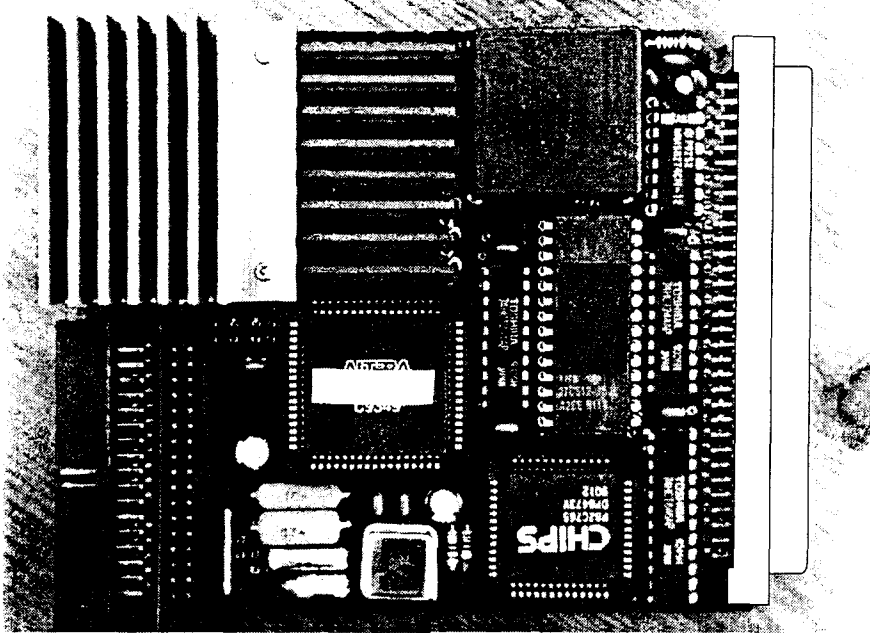

- * *3 Times Faster*
- * *68020 processor*
- * *4M bytes of RAM*
- * *2 Disk drive ports*
- * *CENTRONICS port*
With FREE printer cable
- * *£275.00 + £5 postage*

*To Order please send a cheque
drawn on a U.K. Bank for
£280.00 payable 'QUANTA' to:*

J Taylor
145, Barrowby Rd.
Grantham
Lincs.
NG31 8AJ

*(for more information
phone 01476 563404)*

QPC News

Albin Hessler

The QPC emulator will be available very soon. The software is ready and is now in the stage of testing. As far as I can see all is working perfectly. The first release is expected for the end of July.

QPC runs on a 486 or a Pentium System under DOS. It does not run under Windows 3.xx or Windows 95. Also there is no chance to run QPC in a DOS-Box under OS2, as OS2 there only emulates a 386. Here using the Boot Manager and a primary partition with a standard DOS installed seems to be the best solution. I found a way to start the emulator on a system that only has Windows 95 installed, though my solution is not very elegant.

QPC comes with a special version of SMSQ/E, where only the drivers to access the PC's hardware are special, the operating system itself is unchanged. QPC-SMSQ/E is configurable to memory sizes from 1MB to 16MB. The possible screen resolutions are the same as with a QXL (QL, EGA, VGA or SVGA). The actually installed graphics card in the system is detected automatically by QPC. The screen resolution is configurable and can also be changed at runtime with the command `DISP_SIZE`. QPC will come with a DOS Config Program, so configuration is not as complicated as with the QXL, where you first need a working QL to run `CONFIG`, then to save the configured program onto a PC formatted disk and finally to copy it back to the PC harddisk.

The mouse as installed with a PC mouse driver program is automatically detected by QPC. The mouse can be connected to COM1, COM2 or as a PS2-mouse. My impression is that the mouse with QPC works much better than with the QXL.

QL format disks can be formatted directly. QPC uses the same QXL.WIN file as the QXL for the WIN-device, where `WIN1_` to `WIN8_` correspond to the QXL.WIN files found on PC drives C: through J:. These need not be physical drives necessarily, as all logical mappings are accepted as well. So a drive can be assigned to be a network volume (MAP) or a local directory (SUBST). The PAR device is connected to LPT1, SER1 and SER2 to COM1/COM2 as defined through the configuration. There are also some SBasic commands to control audio CDs.

Through a special key combination a DOS command line interpreter is started from within QPC, so basic tasks can be performed without terminating the emulation. `EXIT` brings back QPC/SMSQE at the previous stage.

QPC seems to become a universal solution to run QDOS/SMSQ on a standard PC. It might be interesting for anybody who has access to a PC. All former QL users now have the chance to access their old QL-Software without any hardware installation problem. The price of the emulator together with

SMSQE will be about DM 200, which is very reasonable compared with other PC-software. It is planned to offer a special version with an integrated Cueshell that will cost only about DM 40 more. Then an up to date operating system environment will be available with all these beautiful features of SMSQ/E together with an easy file access. ■

A new software program: The Basic Linker

Wolfgang Lernerz

Since I'm the author of this program, please take my laudatory comments with a pinch of salt....

If you are a Basic Programmer, this program is for you: Long Basic programs quickly get unwieldy. To change one single line, you must load the entire program, change the line, and save it again. This becomes quite cumbersome when the program gets larger than about 1000 lines.

It is generally considered better to have a number of small source files, which are then put together ("linked") automatically. This also means that at last one can write the source code with a decent editor, i.e. QD. This is what the Basic Linker does.

The source files have no line numbers. The Basic Linker will take the various unnumbered source files, number them, concatenate them and write the entire program into one single file (the "output file"). This can then be RUN just like any other Basic program.

The Basic Linker can also have the resulting file (which is your basic program) parsed to see whether there are any formal errors, and to make a "_sav" file for QLiberator (which can also be QLRUN).

It is then possible to have the program compiled with QLiberator, and to execute the resulting "object" file immediately.

The Basic Linker can also check whether any specific machine code extension is present before compilation, since the compiled program may later crash if an extension was not loaded at compile time.

I've mainly written this program for myself. I have several large programs (200+ K when compiled), and even tiny changes quickly became nearly impossible. I had previously broken the programs up into several smaller ones - which led to an inevitable duplication of code!

Since the Basic Linker can even call up QD and position the cursor at any line (and/or Procedure/Function definition) you give it, it is now so much easier to maintain my code!

I just hope it can be of any use to others. The Basic Linker is sold by Jochen Merz Software and is available now for DM 49,90 (it requires QD and QLiberator to function fully!).

QL Forever! ■

TF SERVICES

MINERVA

The ORIGINAL system upgrade

MINERVA RTC (MKII) + battery for 256 bytes ram, CRASHPROOF clock & I²C bus for interfacing. Can autoboot from battery backed ram. Quick start-up.

OTHER FEATURES COMMON TO ALL VERSIONS
DEBUGGED operating system / autoboot on reset or power failure / Multiple Basic / faster scheduler-graphics (with 10% of Lightning)-string handling / WHEN ERROR / 2nd screen / TRACE / non-English keyboard drivers / "warm" fast reset. V1.97 with split OUTPUT baud rates (+ Hermes) & built in Multibasic.

1st upgrade free. Otherwise send £3 (+£5 for manual if required). Send SAE, Minerva + disk/3 mdvs.

MK1..£41 (£40) [£43] RTC(MKII)..£66 (£63) [£76]

GOLD CARD (incl. SUPER) compatible

QL SPARES

Keyboard membrane	£12.50 (£12) [£13.50]		
Circuit diagrams	£3.50 (£3) [£4]	68008 cpu	£8.50 (£8) [£11]
8049 IPC	£8.50 (£7.50) [£9]	Serial lead	£11.50 (£11) [£12]
1377 PAL	£3.50 (£3) [£4]		
Power Supply (by sea)	£17 (£16) [£21]		
8301, 8302 or JM rom set	£10.50 (£10) [£11]		

Other components (sockets etc.) please phone

QL REPAIRS

Fixed price for unmodified QLs, excl. microdrives. QLs tested with Thorn-EMI rig and ROM software.

£27 including 6 month guarantee (UK)

QBBS - UKs first QL scrolling Bulletin Board

Megabytes of files. Messages to/from UK/Belgium/Holland/USA/Italy/Germany for a UK phonecall. TANDATA callers add SIX zeros (000000) or wait for 3 seconds of modem tone if dialling manually.

01344-890987 (up to V32bis)

TF Service now on the Internet!

tony@firshman.demon.co.uk

SuperHermes

A major hardware upgrade for the QL now ready and shipping

- All Hermes features (see below for list) PLUS full 19200 throughput not affected by sound
- IBM AT keyboard interface (for UK/US/Germany)
- HIGH SPEED RS232 two-way serial port, ie 5000cps throughput (supergoldcard/qtpi zmodem) at 57600bps
- THREE low speed RS232 inputs (1200 to 30bps). Driver for SERIAL MOUSE supplied. Other uses - RTTY/graphics tablet etc.
- THREE spare i/o lines (TTL) with GND/+5v
- Capslock /scrollock LED connector
- Turbo/keylock connectors
- 1.5k user data storeable in EEPROM

All this on a professional board about twice the size of the 8049 coprocessor it replaces

Cost (including manual/software)	£92 (£87) [£90]
IBM AT Keyboard (acer)	£24 (£23) [£27]
Serial mouse	£13 (£12) [£14]
Capslock/scrollock led (+wire&plug)	£1.50 (£1) [£1.50]
Keyboard or mouse lead	£3.50 (£3) [£3.50]
High speed serial (ser3) lead	£4.50 (£4) [£4.50]

Specify PANEL MOUNTING or IN-LINE

I²C Interfaces

Connects to Minerva MKII or any Philips I²C bus

Parallel Interface gives 16 input/output lines. Can be used for logic level output eg model train controllers. Input direct to motor drivers (eg L293/L298) **£26 (£24) [£27]**

Analogue Interface Each gives 8 analogue to digital inputs, and 2 digital/analogue outputs. For temp measurement, sound sampling etc. **£31.50 [£29] [£32]**

Data sheets (analogue/parallel) **£2.50 (£2) [£3]**

Control software/manual (Superbasic extns) **£2.50 (£2) [£3]**

(First interface purchase includes free 15D/9D lead)

COMPUTER CLEANER

High Spec AC mains filters and spike removers

All in standard 3-pin devices and are plug-in NO WIRING REQUIRED. In their 10th year of production - as old as the Sinclair QL.

2-way adaptor ... **£14** 3-way adaptor ... **£18**
4-way trailing socket **£24** (all UK prices)

Prices incl. AIRMAIL postage & packing. Prices are EC except UK (Europe outside EC) [outside Europe] unless stated otherwise. Ring for UK prices or see Quanta. Payment by Mastercard/Visa/Access/Eurocard/cheque/postal order or CASH. MAIL ORDER ONLY - no callers without ringing first. Send IRC for full list and details.



Holly Corner, Priory Road, ASCOT, Berks, SL5 8RL

TEL. 01344-890986 FAX & BBS: 01344-890987



QL Club International

Poynton, United Kingdom - Mike Keneally

I have been asked to write a potted history of how Club QL began, as I am unaccustomed to writing things of this nature you will have to bear with me.

The Club was formed 88 months ago. How can I be so accurate? Well, we are now on Issue 87. The idea was born out of a sense of desperation. Bill Johns from North Wales placed a letter in QL World (back in the mists of time) which asked for help in using his "New" computer, this was in turn answered by Frank Merrison and then myself, as it seemed we were all in the same boat.

The idea of a help group was talked about and I was asked to be the editor [I know the feeling -editor] as I have been for the remainder of the time we have been around. As with Pinnochio's nose it grew and grew from there.

The basic idea at the time was that we would all help each other to overcome our respective problems as beginners and that has been our main aim ever since. Even now, we still receive letters from complete novices, not as often as we did, but it does still happen. Some of us have not progressed as far as others and are still, as one of the members put it, "Technically Challenged".

We have a wide range of members, some are accomplished programmers both in Superbasic and a variety of other methods such as Qliberator, and then there are the others like myself who are users of this wonderful machine and are very grateful for any and all help sent by others.

At the beginning of our venture we all agreed that the help and advice, programs should be sent FREE of all charges and this is how it has remained throughout the life of the newsletter. The newsletter and programs sent out with it are free to all who want it, we have never charged for any help we provide and it is done on a purely voluntary basis with only voluntary monies sent to me occasionally to cover wear and tear of my equipment.

For anyone who may be interested in writing to us or receiving the newsletter and programs this is how you go about it. The newsletter goes out on disc every month. Your disc should arrive with me by the 28th of the month, any letters you send should preferably be in Quill format ie. a _doc file. The newsletter is then compiled on disc along with any programs received and returned to you 7 to 10 days later. You should send it in a padded envelope (like a Jiffy bag) with a return address label, and a stamp (1st or 2nd class).

For those of you with access to the internet,

there are newsletters and programs in the QL section.

Here is a little something to add to your boot program. This will show the date and time on the screen while you are working with Quill or Turboquill. It can also be adapted to be used with other programs. The technically minded amongst you have probably already done this, but I hope it will be of some use to someone out there, especially those of us who may not be familiar with the Clock program in Toolkit 2. The program simply ensures Toolkit 2 is active (line 10), then opens a carefully positioned small window near the bottom of the QL screen (line 20), sets the ink colour for the clock (line 30), starts the clock going (line 40), and starts your choice of program (line 50). The clock is placed on the bottom line of the display of Quill, between the TYPEFACE and DOCUMENT details. To remove the clock when you go back to SuperBASIC, just enter the command RJOB "clock", and then CLOSE #3. Please note that this little program, as it stands, is unsuitable for use with Pointer Environment.

```
10 TK2_EXT:REMark ensure Toolkit 2 is active
20 OPEN #3,CON_140x10a150x246
30 INK #3,2
40 CLOCK #3
50 EW source_progname
```

(source_progname in line 50 is the filename of the program to be loaded, e.g. FLP1_QUILL)

I hope this is useful to some of you, it's certainly been useful to me when I am sat at the QL and I suddenly realise what time it really is!

The address to write to if you are interested in bringing a new insight and are willing to share your experience in a language we can all understand is:

M. A. KENNEALLY
6 BARNABY ROAD
POYNTON
CHESHIRE
SK12 1LR UNITED KINGDOM
TELEPHONE: (+44) 1625 878207
FAX: (+44) 1625 260072

Happy Qling ■

QTYP News

The disk version of QTYP is V2.17, with QTYP itself being V2.05, QTYP_DED being V2.06 (now it can be resized larger than 512x256 pixels) and QTYP_FILE being V2.04 (it now recognises all text87 text files, including _T91!). Updates are available through Jochen Merz Software under the usual conditions. ■

QL Writer's Package

Billerica, Ma. USA - Gary Norton

The QL Writer's Package contains Geoff Wicks' text programs Style-Check and Thesaurus. These programs can be purchased together (as the QL Writer's Pack) or separately.

Since the programs operate individually, I will discuss them as such.

STYLE-CHECK

For those of you that sometimes uses that other operation system, Style-Check will be recognizable (I hope my using the US's spelling with z instead of s and omitting 'me' on such words as program (programme) doesn't turn off the non-American readers). In Microsoft's Word word-processing program, and others, the Grammar option under Tools offers a similar tool.

Style-Check is meant to be booted from Flp1_. If you want to use it from another drive or a hard drive, you have two options to help you do so. With the Gold Card, Super Gold Card, or QXL card, you can use the Data_Use/Dev_Use commands. With a standard QL, there is a Boot_TK2 file that has a Data_Use that can be amended.

Style-Check will not run on an unexpanded QL. You will need at least 256 KB of memory and a disk drive. Though not required to run the program, a faster CPU is highly recommended. With the 68008 CPU, the progress through a document is comparable to the speed of a standard typist. It will take a considerable amount of time to check a long document.

The purpose of Style-check is to make you a better writer. It accomplishes this task by comparing your document with standard grammatical rules. It offers comments or warnings when your writings do or may go astray of the rules. Once my article is written, I'll run it on Style-Check to see how well I've done.

Style-Check loads with a boot file provided on the program's disk. This loads runtime extensions then executes the main program. If the runtime extensions are already loaded then use the exec (or EX) command.

Once loaded, the menu screen appears. You'll notice it is not a Pointer Environment program.

This may be a good feature for some and a shortfall for others. The screen is separated into two parts. The top section allows you to load a file to be checked, the check options, the help option, screen repainting, and exit. The bottom half allows parameters and defaults to be set. Press the highlighted letter in the top options and with the CTRL key for the bottom options.

DOCUMENT:	Flp1_tutorial.doc
LETTERS:	3140
SYLLABLES:	1108
WORDS:	690
PHRASES:	85
SENTENCES:	41
AVERAGE SENTENCE LENGTH:	16.7 words
* LONG WORDS:	17%
PASSIVE:	15%
PUNCTUATION FREQUENCY:	Average
READABILITY INDEX:	9.91
ESTIMATED READING LEVEL:	Secondary School Pupil

* Indicates a possible weakness in this document.

Press ENTER to continue.

Style-Check is a multi-tasking program. However, I discovered everytime I switch to and from it, I need to press the F4 key to repaint the screen. There is also a tendency for the computer to freeze when switching back to Xchange from Style-Check.

A very good feature of Style-Check is that it will check a document in any wordprocessing format for the QL: Quill, Text87, Perfection, and ASCII files. Type in the file name and the program decides what format it is.

Quick Check gives a count of letters, syllables, words, phrases and sentences. Also, it gives average sentence length, long word (3+ syllables) percentage, use of passive verbs percentage, punctuation frequency, readability index, and estimated reading level.

Pressing F1 displays the help file. It gives a definition of all the features of Style-Check. It is basically a manual incorporated into the program.

Standard Check reviews the document, sentence by sentence. I've discovered you may want to adjust the scrolling speed. This is done from the configuration screen under Defaults. The default scroll speed on my computer with the

Super Gold Card is just too fast. I have set mine where it pauses after every sentence. Press the space bar to stop a scroll. Continue by pressing the enter key.

Warnings are given if the default parameters are surpassed. If the average sentence length is > 25 words, a warning is sounded. Look for run-on sentences if the warning is surpassed.

The warning level for long words is 15%. The manual recommends that you use this as a guide for what audience you're writing for. Try to match the complex words usage to the levels given in the manual.

CONFIGURATION SCREEN			
DELAY:	200	BARBER:	234
SENTENCE LENGTH:	40	LONG WORDS:	25%
POSTPONE:	Yes	PREP/CONJ:	Yes
WORD REPEITION:	3	WORD COMMENTS:	Yes
PRINTER:	Epson	HIGHLIGHT:	Bold

← move to item ++ adjust item ENTER to continue Save defaults

*HELP: Controls the scrolling speed (advised = 200).
Set to -1 for indefinite pause after each sentence.
Set to 0 for continuous scrolling.

Certain types of writings carry a fairly high level of passive verbs. Normal writing should be at or below 20%, when the warning is issued.

Punctuation frequency gives five levels, very low, below average, average, above average, and very high. Though all the rules about punctuation are not incorporated, the frequency can tell whether the writing will be unclear or choppy.

Style-Check uses the Flesch-Kincaid Readability Index. This looks at the average sentence length and syllables per word. The index is numeric, where a level under 7.00 would be appropriate for children and over 13.00 for a higher educated audience.

The estimated reading level gives a rough estimate of the education level required to understand the document. There are five categories used. This differs with other style checkers, such as the one in Word, where a grade level is given. This was not used because, depending on which test is used, the grade levels can differ dramatically. I am in agreement with this. In my experience with Word, where three different tests are used, they can vary several years with the same document. The categories given are Under 11, Secondary School Pupil, Average Adult, Further Education Student, and Graduate.

A WARNING or COMMENT is given if a fault (or possible fault) is found. A warning almost always indicates a problem where a comment suggests there is a problem. An example of a comment shows whenever an apostrophe is used.

I use the quick check to give an indication of how my writing is progressing. Do I have it written at the level of my audience? Are there any strong indications that the writing needs repair? If I'm not happy with what the quick check report shows, I then use the standard check and go sentence by sentence to find where I can do my corrections.

Output options are to the screen (the default), a printer, or a file. There are currently two printer drivers included. They are for Epson compatibles and HP inkjet compatibles. The manual suggests that if your printer is not one of the above, turn off the highlight option, and you should get satisfactory results. To get the output to disk, under the printer options, select Disk and set Output to the directory and file name you want it to load it to. You're also allowed to set the baud rate to send to your printer. The default is at 9600, which is what most printers expect.

Style-Check comes with a very handy 24 page manual. For those that don't like reading manuals, it offers a one page Quick Start section that gives all the essentials you'll need to get going with this product. The manual goes on to give an explanation of all the statistical checks, giving why they're important and why the caution and warning levels are set to where they are. The next section explains the other (default) bottom screen settings. The last

half of the manual is an appendix listing words that often cause problems, such as being misleading, having several meanings, or may be ambiguous. I've found that just by reading the manual, your writing will improve. It will make you think of how you're phrasing your sentences and selecting your words as you write.

Overall, I am very impressed with Style-Check! Anyone that writes often or any student should have a

copy of this program. It is easy to use and if allowed, will make you a better writer. I highly recommend Style-Check.

There are three things I would like to see incorporated into the program. I would like better multitasking. As mentioned earlier, I've had several crashes when multitasking with Xchange as well as with Perfection SE. I haven't tried it with an editor. Maybe it will work more smoothly with them. I would also like to see it working in conjunction with the wordprocessor so you'd be able to make corrections as you type. Lastly, when it issues a caution or warning, I would like to be able to access the rule it is cautioning me against. Where F1 displays the help file for the workings of the program, maybe F2 could call the rules.

QL-THESAURUS

The QL-Thesaurus loads in the same way as Style-Check. I have both programs loaded onto the same disk with a boot program that allows me to select whichever program I want.

The hardware requirements are a QL or compatible with at least 640K of memory. The dictionary data base is 390K long, another data base 13K and the program 60K. It seems to run well, albeit slowly on a QL with a 512K Expanderam attached. If you're planning to multitask, at least a Trump Card is recommended, but a Gold Card or Super Gold Card is highly recommended.

QL-Thesaurus is based on the Roget Thesaurus in its format. It has a dictionary of approximately 23,000 words and phrases. These are categorized into 1,000 groups. For anyone not familiar with

```
This document contains a large number of style faults to illustrate the
many features of the program.
COMMENT NUMBER: "The number of..." is singular, "A number of..." plural.
actually, you could say there is a scenario of an ongoing fault
situation, which necessitates a prioritising of time to normalise the
document.
High proportion of long words.
COMMENT ACTUALLY: Can this word be omitted?
COMMENT THERE: Singular or plural verb? Check subject!
COMMENT SCENARIO: Almost always jargon - try SITUATION.
COMMENT ONGOING: Jargon word - use CONTINUING.
COMMENT SITUATION: Usually jargon if preceded by a noun.
COMMENT WHICH: If use in defining clause, THAT is usually better.
COMMENT PRIORITISING: Use GIVING PRIORITY.
COMMENT NORMALISE: Use RESTORE TO NORMAL.
```

Press ENTER to continue.

Roget, the groups help select the meaning of the word you're looking to find the synonym to. QL-Thesaurus performs two types of searches, Simple and Complex. Simple is when there is only one meaning to a word and complex when you must decide which meaning you're looking for.

The dictionary data base is modifiable on a text editor. The format of the data base is: thesaurus_086_562_593. The numbers are the group numbers associated with the word. For an ambitious person in North America, this may be a good feature. The dictionary has only British spelling. An example of a problem a North American writer may run into is if, using my example at the top of this article, he selects PROGRAM. The program's response is "THE FOLLOWING WORDS ARE IN THE DICTIONARY: programme." Another example is if COLOR is chosen. The words in the dictionary selected are coloration and discoloration. You need to remember to include the "u" between the o and r.

The aforementioned ambitious person could include the American spelling of words. I'm sure Geoff Wicks wouldn't mind someone doing this and making it available to other users. Unfortunately, I am not that aforementioned person!

The initial screen is similar to Style-Check's. You select your search options from the top half of the screen and set your parameters and output settings from the bottom half.

The first option available is Dictionary. It asks for the first letters in a word. All the words and phrases in the dictionary are then displayed. Find the word you're interested in and select it. You're next told which groups it's in and asks you to select. Select the group by the meaning you want by moving with the cursor keys and hitting enter. If you would like to check more than one group press the space bar instead of enter and the group gets "marked". When all the groups are marked, press enter to view the groups one after the other. A list of the words contained in the groups are displayed and you select the word you're interested in using.

Not all words in the group are synonyms. For example, when I selected banjo from the letters ban, the group "The Senses - Sound - Musical Instrument" is selected. All types of instruments and sound makers are listed.

Word works the same way as Dictionary, except instead of listing words beginning with the letters entered, words containing the letters entered anywhere in the word are displayed. As the manual example, type in "tip". Besides words like tipsy, you'll find phrases like on the tip of the tongue, as well as words like sTIPend. Once a word is selected, as in Dictionary, you're given the list of group its associated with.

The next selection, Groups, you are asked for the number of the group you want to search. Luckily, a groups_doc file is included on the disk. Print it out for quick reference. After the group is selected, a list of the groups is displayed, starting with the one selected. Press space or enter to list the words in the group. Groups is useful to find opposite meanings because the groups are arranged in opposite pairings. Group 58 is "Abstract concepts - Order - Orderly" while Group 59 is "Abstract concepts - Order - Disorderly".

To find the antonyms of words, from Dictionary or Word, select the word you want the antonym for. When the groups are listed find the one with the meaning you want and note its number. Next go to Groups and select the number you've chosen. The group with the next couple of higher numbers should have the antonym you're looking for.

The Help option works, again, like its Style-Check counterpart, by giving meaning to the command options, then with a comprehensive explanation of how they work.

The remaining options, Quit, F4, Printer, Output, Beep, and Rate perform the

same as on Style_Check. Form allows either one or three column output.

Any writer can benefit from QL Thesaurus. When writing, I constantly am trying to think of just the correct word to use. This program gives them to you instantly. Contrary to Geoff's ads, this program, as well as Style-Check are very easy to use. This program comes with a handy 12 page manual that explains all its features and also gives copies of the important screens to allow you to easily understand how the program works. Anyone that has ever used the Roget Thesaurus will feel right at home with QL Thesaurus.

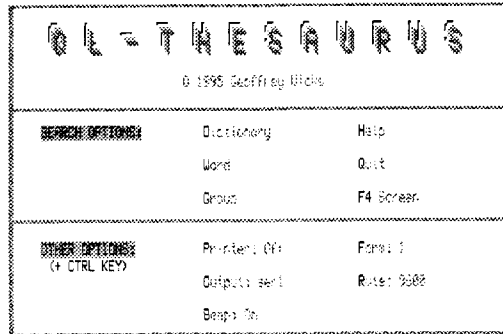

SELECT ONE OF THE OPTIONS SHOWN ABOVE :

345 Material concepts - The Physical World - Marsh

bag
fan
marsh
warrior
reuss
reud
peal
causagy
sluggish
sluggish
slough
slush
spraggy
squares
slap

SEARCH WORD: MARSH

MODE: Dictionary

Press ESC to continue, GO to end

To make QL Thesaurus even more user friendly, I would like to see the multitasking perform better. I had the same problems as was noted with Style-Check. Maybe using QPAC 2 or some other front end will alleviate this problem. Without using a front end program, multitasking is troublesome. Also, as noted earlier, the thesaurus' dictionary gives British spelling. It would be helpful for the North American user to have both spellings. Finally, I would like to see the thesaurus work in conjunction with the wordprocessor or editor like a spell checker does. I would like to be able to select a word in the document and by pressing a key or key combination, be able to activate the thesaurus and have features such as word replace.

Another feature I would like to see on both programs is an easier way to select the device the program is operating from. Why not be able to select dev\$ and have it filter through all steps of the program? This would be much easier than having to use the Data_use/Dev_use options.

Geoff Wicks did a commendable job with these two programs. With a spell checker, such as with Perfection SE, the QL Writer's Package offers the writer all the tools needed to improve one's writing output. Its a great package for the student or writer of QLToday articles. With the few features I've commented on, I think the QL Writer's Package would rival any offered anywhere for any operating system. They are easy to use and offer all the important features a writer would ever need. They will get much use in my household, between my childrens' school papers and my own writing.

Now, to see how well I stack up, following is a printout of Style-Check's analysis of this article. Though not good enough for a Doctoral Thesis, it's an improvement over what it would be without Style-Check. Here goes.....

DOCUMENT:	win1_temp_write_doc
LETTERS:	11834
SYLLABLES:	4127
WORDS:	2621
PHRASES:	325
SENTENCES:	181
AVERAGE SENTENCE LENGTH:	14.4 words
LONG WORDS:	13%
PASSIVE:	18%
PUNCTUATION FREQUENCY:	Average
READABILITY INDEX:	8.63
ESTIMATED READING LEVEL:	Secondary School Pupil

The QL Writer's Package costs £25.00 (or 65 Guilders in The Netherlands) from Geoff Wicks, Bertrand Russellstraat 22, 1097 HL Amsterdam, The Netherlands. Telephone: +31 20-692 1521. The Syle Checker and the Thesaurus may be purchased separately for £15.00 (39 Guilders). Both programs are also available from Quo Vadis Design and QBranch in England. ■

A Trip to Boston

Albin Hessler

Pictures by Don Waltermann

This year NESQLUG (*New England Sinclair QL User Group*), which in fact is also aQuanta sub-group, organised the annual North-American QL meeting on Saturday, May18th in Bedford about 20 kilometres from Boston. I had already arrived in Boston on Thursday evening. I had decided very late to go there and could only get a flight from Stuttgart via Brussels to Boston on Thursday.

I only live some kilometres from the Stuttgart Airport, so it was no problem for me to reach the aeroplane on this side of the ocean, but once I had arrived in Boston on a heavy raining Thursday evening, how could I reach the Ramada Inn in Bedford, having learned that public transportation is not in preference over there?

By chance the gentleman who sat beside me in the aeroplane was very kind and pleasant (he is working at Digital, so you can imagine what we talked about most of the time). He confirmed my prejudice about public transportation in the USA and helped me in finding out that there existed a shuttle Taxi going to Bedford.

After the immigration procedure (the immigration officer treated me with exceptional kindness compared with some people before me) I had to wait about three quarters of an hour until the shuttle finally picked me up. The driver announced he would charge me \$34 but at least I was lucky to sit in the dry finally. A normal taxi would certainly have been even more expensive. All roads in and around Boston were completely blocked, so the shuttle driver tried some tricks to find his way through the backyards of Boston. It did not help very much and so it took about one and a half hour to reach the hotel in Bedford.

The next morning I met two famous QL specialists from England at breakfast. As usual they had travelled by bicycle from Boston Logan Airport to Bedford. They told me that it had taken them five hours cycling through the awful rain drenched to the skin, trying to find their way to Bedford via small roads with the remaining parts of a completely soaked map.

Anyway, Stuart and Tony had not lost their good humour and were prepared to go to Boston by bicycle the same day again, especially as their knowledge about public transportation was about the same as mine. They had seen bicycles in the

nearby shopping centre and proposed that I hire a bike and joined them. The bikes were only toys so we gave up this plan very soon. We took all our courage to ask the hotel manager about the chance to find a bus or something similar to go Boston. We were prepared for laughter, so the answer that right across the street a bus would stop about every half hour

which would take us to the Boston T-Train, something like a subway, astonished us a lot. In fact there was a tiny little bus sign with a T in a circle, no schedule or anything else to point out a bus stop, and after a few minutes a real bus came. The driver charged us one Dollar each, a ridiculous sum compared with what we have to pay for a similar fare here in Germany. The T-Train was 85 cents and took us right away to South Station in the middle of Boston City. One of us was already hungry so we agreed to take lunch in a Chinese restaurant in the nearby Boston China-Town. After that I went out for sightseeing, and as the only thing I had heard about was the Boston Tea Party Ship, I proposed to go there. I do not know if that was the best idea to drag the two

Englishmen directly to the Tea-Party Ship (read about the history, if you do not understand what I mean). They did not resist, so I hope they did not suffer too much. In any case, we had a lot of fun that afternoon.

When Stuart's wish to find a cheap modem for his PC was finally fulfilled, after an extra ride with the T-Trains Green Line, Bedford saw returning three new born specialists in Boston area public transportation.

The same evening, a first meeting was arranged by the NESQLUG. Besides the organisers, there were visitors from all over the United States and from Europe. I was astonished that so many

were accompanied by their spouses. Al had arranged to meet in the hotel lounge and to go to a small restaurant in Bedford for Dinner together. Some of us ordered the local speciality, twin lobsters, for a ridiculous price, while others like me preferred fried fish. During the evening some QL anecdotes and other stories made for an interesting and funny atmosphere.

Upon returning from the dinner more visitors had arrived, and a well-known QL-dealer from Germany with whom I had arranged to share the hotel room waited impatiently for me as the hotel manager refused to give him the key. This problem was quickly resolved and a shower bath made him forget some of the trouble with his delayed flight and an influenza. So he joined the QL specialists round in the hotel bar. There the actual QL situation and especially the question of a QL magazine was discussed at length. Jochen

presented his brand-new QL Today magazine, which he had produced in a very short time.

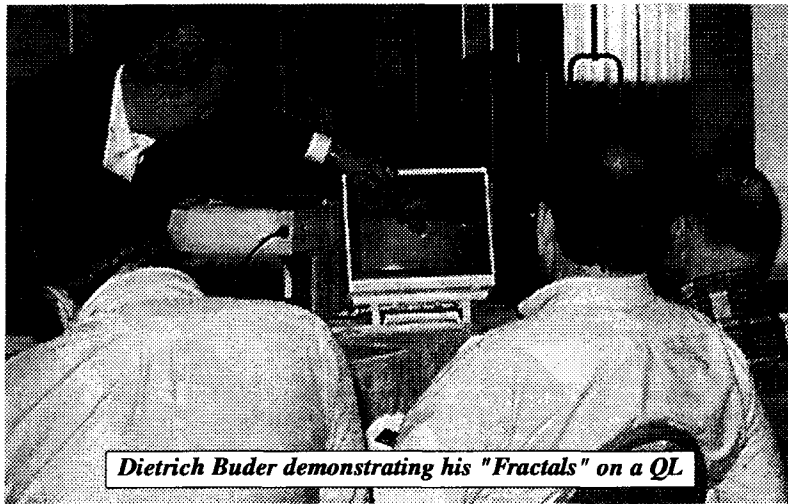

Dietrich Buder demonstrating his "Fractals" on a QL

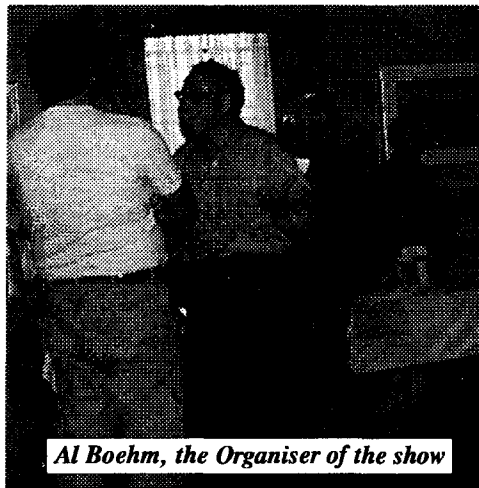

Al Boehm, the Organiser of the show



Albin Hessler explains QPC

The next morning the official QL-Show took place in the hotel's Lexington Room.

- Jochen Merz (Jochen Merz Software) showed his software palette and as always was occupied by making demonstrations and updates.

- Tony Firshman (TF Services) presented and explained his SuperHermes replacement for the QL.

- Stuart Honeyball (Miracle Systems) gave explanations of hardware developments to come and the new QL magazine QL Today.

- Frank Davis (FWD Computing), the American dealer, offered his complete palette of QL hard and software.

- The QL-Emulator for the Macintosh was demonstrated on Al Boehm's PowerBook.

- Herb Schaarf demonstrated his QL in the paperboard box.

- Tim Swenson gave us some explanations about the Internet in general and the QL in the Internet in particular.

- I myself had the occasion to demonstrate Cueshell running on QPC on a PC-Notebook.

- Many others presented their hard and software developments. Present were Robin Barker, Dietrich Buder, Bill Cable, John Gregory, Jim Hunkins, François Lanciault, Mel Laverne, Gary Norton, Ian Pizer, Don Waltermann, ... all those whose names I have forgotten or forgotten to mention please forgive me, especially the nice couple who took me to Dinner in their car the evening before (please drop me a line).

The hours of the show passed very fast and I think all visitors were pleased to get the latest information about what is happening in the QL scene today. In the evening we all met for a common Dinner in the Hotel and had a good meal (which helped in destroying my prejudice about

American food). The pleasant evening with small talk, discussions and a questionnaire ended with a sing out arranged by Dorothy, Mary and Al.

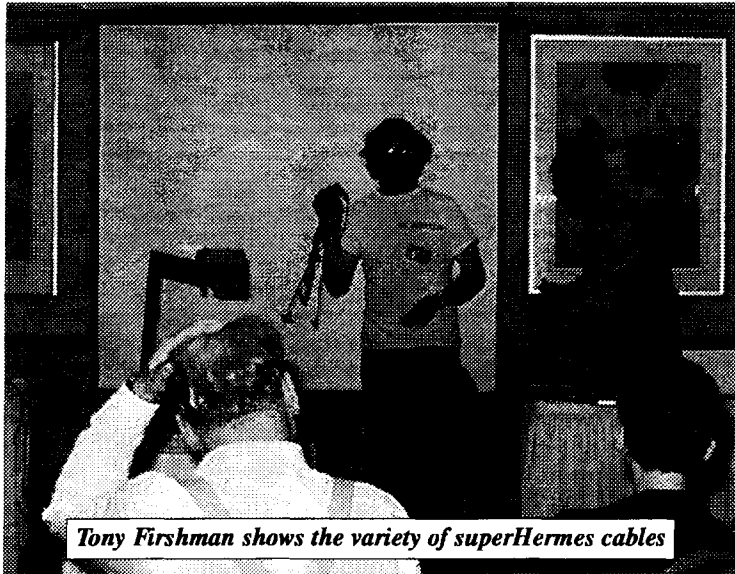

Tony Firshman shows the variety of superHermes cables

On Sunday Dorothy and Al had invited the remaining QL community to their private home. The house is fairly well equipped with computers, there are a number of Qls, a PC and a Macintosh PowerBook. There was good occasion to discuss QL questions and the chance to get problems solved by the QL specialists. Dorothy generously offered us drinks, sandwiches and apple-pie for lunch. Let me express my special

thanks to her this way and apologise for the disorder in which we left her house.

In the afternoon people started to travel home, some had a fairly long travel by car before them, others had to reach Logan Airport by bicycle. I was out for a computer store, as I searched for a special part for my PowerBook. Gary was so kind to drive me there.

Thank you very much Gary.

Al and Dorothy Boehm, Bill and Mary Cable and Gary Norton with his son Eric have organised a very successful QL-Meeting. I apologise if I have forgotten somebody of the NESQLUG organisers. My special thank goes to all of you.

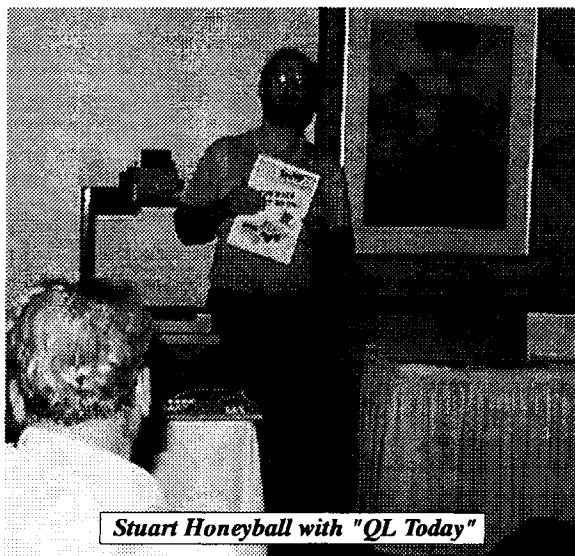

Stuart Honeyball with "QL Today"

On Monday I had the whole day for sightseeing in Boston, until my flight back to Brussels started in the evening. ■

Jochen's note: I enjoyed the show very, as well as visiting the USA once again. If there is another show next year I'll definitely come, and everybody from Germany who would like to come as well should contact me as soon as another show is announced - it's worth it!

S.J.P.D. SOFTWARE

WWW Page <http://www.di-ren.co.uk/sjpd/homepage>
CompuServe ID = 101325,2750
Internet Email stephen.johnson@almac.co.uk

36, Eldwick Street,
Burnley,
Lancashire,
England.

BB10 3DZ.

Tel / Fax +44 (0)1282 701767.



QL HACKERS JOURNAL.
INTERNET GUIDE TEXT FILES.
UNGIF Release 094.
7 DISKS OF RELIGIOUS CLIP-ART.
XCHANGE Version 3.90L.
ZEXCEL. SPECTRUM EMULATOR.
INFOCOM ZIP COMPILER.
GHOSTSCRIPT 2.6.1.
QL INFOZIP RELEASE 004.
MOLECULAR GRAPHICS V5.13.
PRETTY GOOD PRIVACY.
C68 Release 4.21b.
"C" TUTOR (SJPD Version.)
PERSISTENCE OF VISION.
M. EDWARDS DEMO DISK.
G. WICKS DEMO DISK.
QL WAR Version 3.02.
Z80 CROSS MODULE ASSEMBLER.
POINTER MICROEMACS.
SALVATION ARMY CLIPART.
ST CLIP-ART.
LINEDESIGN FONTS.
MONOP. (MONOPOLY)
TREK.(STAR TREK)
LIB LIST.

THIS IS A SMALL SAMPLE OF THE
150 + PACKAGES ON OFFER.

Please see catalogue or contact me prior to ordering as
some packages come on more than 1 disk.

*Plus 64 disks of the best
assorted in QL Public
Domain & Shareware.*

*A full range of emulators for
use on either IBM
compatibles or the Amiga.*

*Over 200 disks of classic
literature & assorted text files.
Including the complete works
of Shakespeare.*

**Gold Card &
Super Gold Card Users!**

**IBM Branded
Extra High Density Disks
Now In Stock**

**Only £2.50 Each Or £22.00 For 10.
Fully Inclusive Of UK P & P.**

QL Pre-Copied Disks Are £1.25. Each, Inclusive Of Media And Return Postage.
For A Catalogue Disk Which Details Over 500 Disks Of PD & Shareware & Text
Files Offered. Send A Formatted Disk And Return Postage.

"From The Nurse Helping To Keep The QL Alive."

10/06/96.



We hope to have more pictures from Al Boehm in the next issue.

The Genealogy Bug

Wokingham, United Kingdom - Chris Boutal

This is not about a software bug, but concerns a condition that affects more and more people today. Searching for ancestors has become one of the fastest growing hobbies in the 90's and QLers are affected like everyone else - perhaps more so.

Some years ago the erstwhile magazine QL World published a survey of its readers on what they used their QLs for. I don't remember the full details, but there were about five subjects that stood above the "other" category including the obvious Word Processing and the not so obvious Family History.

Genealogy and computers do go well together after all. Anyone who has done any family tree research will know that they soon acquire large mounds of data. Remembering it all, how it relates to the family and where it came from soon exhausts the human brain.

My personal interest began when I was about sixteen years old. I began asking questions of my parents, grand parents and then visiting Aunts, Uncles and the rest. Quite soon I had drawn several family tree diagrams and had discovered some of the basic laws of Genealogy.

Law 1. However big the sheet of paper, a family tree will always run out of room before you have finished it. Quite often there will be large blank areas where you do not need them.

It was not long before I had extracted all I could from my relatives and I was surprised at how little they knew. I had no idea how to get any further. Then one afternoon a few weeks later, my grandmother handed me a booklet she had received some four years earlier from a relative in the

United States. This was something of a shock since neither had she mentioned it when we were talking about relatives nor had I any idea that we had relatives in the United States.

Law 2. Relatives will insist that they know nothing that will help with the family tree until you have done hours of research, when they say "Oh yes, I knew that!".

It turned out that a distant cousin of hers had caught the bug and compiled data on about 120 relatives with their dates and places of births, etc. She had done this mainly by writing to people. It turned out that we had cousins in South Africa and Ireland as well as the US.

I spent days turning this lot into a family tree and came up with another law.

Law 3. The more research you do, the more conflicting data you acquire about who your ancestors were and where they came from.

After this the bug lay dormant for about 20 years as A levels and other things intruded.

Reawakening occurred in 1987 (I was by now married with children of my own) when my wife Helena decided to take up evening classes in Family History. Her motive was to take up something outside the family to restore her sanity. This worked well but did nothing for mine as the bug took hold again.

The course opened up new horizons on how to find ancestors and soon Helena was off to London and other places to do "research". We even went on holiday to Wales to look up family gravestones and visit the Haverfordwest record office. We also discovered the IGI (International Genealogical Index) which is a huge computer index of mainly baptisms and marriages compiled by the Church of Jesus Christ of Latter Day Saints. You can find copies of it in most major libraries on microfiche, and is also know available for searching on CD ROM in some places. Helena came home with pages and pages of Boutals, Bowtals, Boutells and the like. I am fortunate in having an unusual surname as it does keep the volume down.

Now as well as acquiring children in the early 80's I had also bought a QL in 1984. Until then I had not found much practical use for it apart from writing SuperBasic programs for fun. It remained with an AH ROM and 128k of memory - "as new". Inspiration began dimly to dawn. If we took all this IGI stuff and sorted it on place and then date we would be able to see the families much more clearly. I soon got stuck into typing all the data into Archive and writing various procedures for sorting it and listing it while tracing the family

back through London, to Bishops Stortford and beyond.

Soon however the limitations of the standard QL began to become a problem. First the keyboard membrane packed up and then the 128k limit prevented further additions to the Archive database and Archive's sorting capabilities were not adequate. Surprisingly perhaps the microdrives were not a problem at this time. A Schon keyboard and a trump card transformed the system. By loading the entire microdrive into a ram disk at the beginning of the session and copying it back at the end increased the capability significantly and performed well for another couple of years.

By now the Archive procedures had grown to huge proportions and could print family trees. The basic method for printing was later translated into the three versions of QL Genealogist and now into the recently released "Genealogy for Windows" which runs on IBM PC compatibles.

QL Genealogist was born because Archive was too slow and inadequate for the large trees and quantities of data that we had now amassed. I decided to rewrite the whole thing in SuperBasic and compile with QLiberator. From the start I wanted a program that did what I needed it to do, but was also of a good enough quality to sell commercially. The first copies were sold in 1990 at a Quanta workshop in Worthing - and it was here too that I first met Dilwyn Jones. So began a long and fruitful collaboration that lasted through three versions of Genealogist, up to the present pointer environment version.

Why are so many people driven by this 'bug' to search out their ancestors? I don't really know, but I can tell you that it leads you into all kinds of other areas such as social history, local history, military records, the church, transport, you name it. It is much more than putting names on charts.

Everyone one alive today has unbroken lines of ancestry going back to the dawn of creation - millions of years. Yet you are lucky if you can trace the last 400 with any accuracy. To me it is one never ending detective story that you can pick up and work on when you have some time and put down again when you haven't. You search out clues and you make deductions and then you try to prove your case from the evidence. Eventually you find the answers and the exhilaration of finding

your own family after hours of searching has to be experienced to be understood.

I have discovered 4th, 6th and 7th cousins that I did not know existed through sharing interests and finding others whose family line has joined up with ours in the 19th century and beyond. Don't be put off by road blocks. I have heard people say "Oh I cannot trace my family, the records were destroyed". It is very unlikely that ALL the records of an entire family have been destroyed. It is true that church records have been lost, various acts of destruction, fires and general neglect have claimed others - but there are many sources of information and quite often you can get round these problems

by looking somewhere else.

Law 4. Family hearsay is nearly always wrong, but always contains a vital clue which you overlook and rediscover years later after hours of research.

After talking to relatives the best place to visit is St Catherines House in

the Aldwych, London which holds Birth, Marriage and Death records from 1837 to the present. You can just turn up there and look in the "indexes". Each year is split up into the quarters March, June, September and December and then arranged alphabetically by surname. The entry gives you the christian names and place (and some later entries give a bit more) of the event and a reference. To get the certificate you need the reference and '5-50 (at the time of writing).

Before you go you need to have at least a rough idea of the date and place of birth, marriage or death of the people you want to trace. The more common the surname, the more difficult it is to know if you have the right one. Unusual christian names are a big help too. Finding one person gives you information which helps to find the next, and so on.

After a few generations you get back to beyond 1837 - so where do you go from here? There are now several options. Parish records are held at County Record Offices where you can go and search them. It is usually a good idea to ring in advance as you may have to book a microfilm reader (its a popular hobby remember!). Records here go back to the 1500s if you are lucky.

The IGI is another good place to go. This is the computer index mentioned earlier and is arranged by county and then surname.

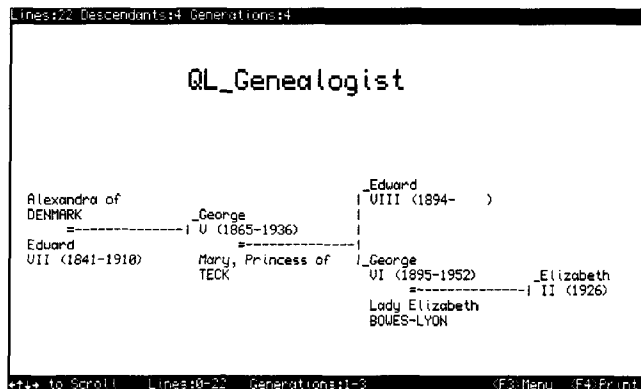

The Census is an excellent source as it shows whole families grouped together. It is available for England and Wales at the Record Office in Chancery Lane, London (and some other places). You need to know where the people lived and if possible an address (sometimes available on marriage certificates, etc). Some areas have been indexed by local family history groups and these are a great help as you can just look up the surname. Censuses are available for every tenth year from 1841 to 1891. (There is a rule that personal details from the census cannot be made generally available for 100 years).

There are many other more specialised sources such as wills, graveyards, military records, professional publications, newspapers, title deeds, trade directories, telephone directories and so on. These are described in the many publications that are available on how to research your family history.

Finally you can join a local family history society (most counties have one) or the Society of Genealogists who have an extensive library of their own. There is no cure for the Genealogy bug.

* Chris Boutal is the author of the QL Genealogist series of programs for the QL and the PC. The above screen dump is taken from the QL version of his programs. ■

The Black Hole

Aberdeen, United Kingdom - Norman Dunbar

Printers are a common cause of hassle when you are using a computer. I know, I have to use a number of them, at home and at work. This, however, is not really an article about printers as such. It is an article about how you can get around some of the problems that using a printer can cause when you are the author of a [commercial] program that may or may not attempt to print.

I wrote a program called WinBack a number of years ago, and as it progressed from a glimmer in my mind to a fully fledged commercial program a number of problems reared their ugly heads, printing being one of them.

In the program, I had a number of things to consider, some of these being :

- Is the user requesting any printing to be done?
 - Is there a printer or a file attached to the printer channel?
 - What do I do if I get an error on the printer?
- and so on.

If the user requested a listing from the program, a flag was set in the program. This flag was checked each and every time before any printing

was attempted, as follows :

```
IF printing% THEN
  PRINT #printer, 'Something .....
```

Now admittedly this is not too difficult, but I had this sort of thing in a few places within the program so there were a number of checks being made. So the first thing to do was to get all printing done from a central place like this :

```
DEFINE PROCedure lprint(text$)
:
  IF printing% THEN
    PRINT #printer, text$
  END IF
:
END DEFine
```

So now I only had one place that was doing anything that involved the printer. This is fine, but, what happens if the printer channel is attached to a disc file instead of a device ? Well as WinBack was compiled using Digital Precision's TURBO compiler, I added some error trapping and checked for various errors such as 'Not found' etc. These were dealt with individually by giving the user a message and an option as appropriate.

The next stage was to do away with all of the testing, admittedly only one test now, so I wrote the following device driver which acts like a 'black hole' in that you can pour anything into it that you don't want, but you won't get anything out of one (for more information on black holes, read Steven Hawking's A Brief History Of Time !!!)

This was my first device driver so it is very simple. It was written in 1991 but I have used it since then and never had any problems with it. The code in this article has been imported directly from the source code and is thus an accurate representation of that which is in use on my own machine.

I have removed most, if not all of the comments from the code in order to get this article down to the requested number of pages, however, I will explain what is going on as we progress through the listing.

THE SMALL PRINT

Before we start, although I retain full rights to the code in this article, you have my express permission to use it, alter it and give it away to anyone you want provided that :

- you do not claim to be the author
- you do not charge any money for it

Here endeth the small print !

The Black Hole - Listing & Explanation

First of all, we start with a list of what QDOS traps the device can handle. Any other calls will generate an error.

```

*-----*
* The following list gives details of what is allowed in QDOS speak *
* * *
* TRAP #1 - not applicable. *
* TRAP #2 - IO_OPEN & IO_CLOSE both work ok. *
* TRAP #3 - IO_SBYTE, FS_CHECK, FS_FLUSH, FS_POSAB, FS_POSRE *
* IO_SSTRG, FS_SAVE all work ok. *
* IO_PEND, IO_FBYTE, IO_FLINE, IO_FSTRG, IO_EDLIN *
* FS_MDINF, FS_HEADR, FS_LOAD all give ERR_EF. *
* All other D0 codes give ERR_BP. *
* *
* Note that IO_SSTRG & FS_SAVE return correct parameters as if they *
* had done something, ie, A1.L = A1.L + D2.W, D1.W = D2.W *
*-----*
* Copyright Norman Dunbar *
* February 1991 *
*-----*

```

Now a list of trap codes that are used in the following source.

```

err_ef equ -10
err_bp equ -15
io_sbyte equ $05
io_sstrg equ $07
mt_liod equ $20
fs_check equ $40
fs_posre equ $43
fs_mdinf equ $45
fs_headr equ $47
fs_heads equ $48
fs_save equ $49
mm_alchp equ $C0
mm_rechp equ $C2
io_name equ $122

```

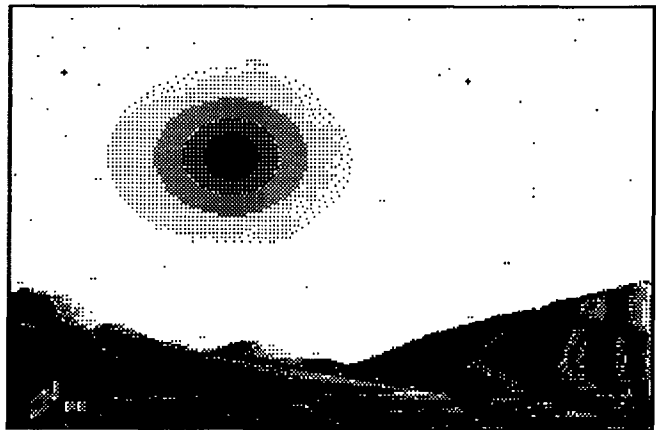

The code, when called must set up a driver linkage block of 4 long words in memory, fill in the OPEN, CLOSE and INPUT/OUTPUT routine addresses in the linkage block then call the Trap #1 function, MT_LIOD to link in the new device driver.

All addresses are relative so the device linkage block must be filled in each time the code is loaded, you must not set up any 'hard coded' routine addresses.

The trap requires that A0.L is pointing at the linkage block. The block consists of 4 long words and the first of these is used by QDOS and will be set up for you by the trap call.

The second long word must hold the address of the I/O routine, the third holds the OPEN address and the last holds the CLOSE address. These are set up in the following part of the code.

```

start    lea.l  drvr_block,a0    linkage block address
         lea.l  dev_io,a1      I/O routine address
         move.l a1,4(a0)       Into its slot
         lea.l  dev_open,a1    OPEN routine address
         move.l a1,8(a0)       Into its slot
         lea.l  dev_close,a1   CLOSE routine address
         move.l a1,$0c(a0)     Into its slot

```

Now all that remains to be done, is to call the trap routine and return to SuperBasic with whichever error code was returned by QDOS. Here endeth the device driver installation.

After the RTS instruction, we have the device driver linkage block where we reserve 4 long words as required by QDOS.

```
        moveq    #mt_liod,d0      Now prepare to ...
        trap    #1                ... link driver into QDOS and
        rts                          exit with any error codes.
drvr_block ds.l    4
```

The Device driver has now been installed. Any calls to open, close or use a channel attached to a black hole device will be directed by QDOS to one of the following code routines.

The first, and probably easiest to follow, is the CLOSE routine. This gets called, surprisingly enough, when a program wishes to close a channel to the black hole device.

Closing a black hole channel is simply a matter of reclaiming the space that QDOS allocated when the channel was opened (see below). The close routine is passed the address of the channel definition block in A1.L and this address is simply passed to MM_RECHP which is the proper memory deallocation routine to use in device drivers.

Close routines never fail, it says in the documentation. In the event that this one does fail, DO will be set to a suitable error code, so we just pass it back.

```
dev_close  move.w  mm_rechp,a2      Reclaim heap space
          jsr    (a2)              And do it
          moveq  #0,d0             CLOSE never fails
          rts                      And exit
```

Any channels that are opened to a black hole device, will cause the following routine to be called from QDOS. This is the open routine in all its glory.

The open routine must first make a call to the IO_NAME vector to decode the name of the device that is to be opened. If this is not for our device, or if an error occurs, we deal with it as described below.

```
dev_open  move.w  io_name,a2       Utility to check device names
          jsr    (a2)              And do it
```

This vector uses 'multiple return addresses' in the event that the device was not found, or if a parameter error was detected. There must be 3 short branch instructions following the JSR above. These are, in order, 'not found' error branch, 'bad parameter' error branch and finally the 'ok' branch.

```
        rts                      Oops, not found error return
        rts                      Oops, bad parameter error return
        bra.s   dev_ok           Yippee !
```

The vector requires that the device name, as a QDOS format string, then the number and type of parameters follows on from the 3 short branches described above. So guess what is coming now ?

```
dc.w    10                      Size of device name
dc.b    'BLACK_HOLE'           Device name
dc.w    0                      Has no parameters
```

We only get to here if the device name decoded correctly and there were no parameter errors. So the open routine must now declare its need for a channel definition block. This device only needs a minimum sized block, which is 24 bytes. The MM_ALCHP vector must be used in a device driver to allocate memory, why ? Because it says so in the QDOS documentation.

As this is a very simple device driver, we don't have any information or parameters to fill in to the allocated block of memory that is the channel definition block. We can simply return to whence we came and on the way out, QDOS will fill in all the relevant details for us. So far so simple.

```

dev_ok      move.w  mm_alchp,a2      Claim channel definition block
           moveq  #$18,d1        24 bytes is minimum
           jsr   (a2)            Go get the space (address in A0)
           rts                    Return any error codes

```

This next routine is called whenever a program tries to write to an open channel attached to our device or tries to read data from the device. We as the device creator, must handle all of these requests in a suitable and legal manner.

On entry to this routine, the registers are set as follows :

D0.B = operation code, top 3 bytes are zero. D1 & D2 are parameters, if required. D3 is 0 on the first entry to the operation or -1 subsequently.

(An operation to perform some I/O may have timed out and is being retried to finish it. In this case D3 will be -1)

A0.L = start address of the channel definition block. A1 & A2 are parameters, ifd required. A3 = Start of driver definition block. A6.L = system variables address.

We must first check to see that a valid operation code has been supplied. Some operations, such as CLS or INK, PAPER etc are totally invalid and should return an error code (ERR_BP).

In this device, any attempt to read data from the channel will give an end of file error, so this is quite easy and we test for these operations first.

IO_SBYTE is the first of the output type operations, so if the supplied operation code is less greater or equal than this, carry on. If not, return ERR_EF and bale out.

```

dev_io      cmpi.b  #io_sbyte,d0    Check for input operation
           bge.s  not_input        It is not input

error_ef    moveq  #err_ef,d0      Return EOF on all input operations
           rts

```

This bit will be called as and when required. It simply sends the user back a 'bad parameter' error.

```

error_bp    moveq  #err_bp,d0      BAD PARAMETER for invalid operations
           rts

```

If we got this far, then we must be doing an output operation on the channel. Try to filter out the easy stuff next.

IO_SBYTE is easy, simply do nothing and return a zero error code to show that it worked ok.

```

not_input   cmpi.b  #io_sbyte,d0    Send a byte, do nothing
           beq.s  exit_ok

```

IO_SSTRG and FS_SAVE require a bit of fiddling. These routines must return some parameters that have been updated to show that the operation took place.

```

           cmpi.b  #io_sstrg,d0     Send a string ?
           beq.s  sstrg_save
           cmpi.b  #fs_save,d0      And save a file require extra code
           bne.s  not_save

```

This is where we fiddle with the supplied parameters. A1.L points to our source buffer for the data being sent to the channel and D2.W holds the data length. In order to show that we 'sent' the data to the channel, we must adjust the buffer pointer. This is done by adding the data length to the original buffer pointer and return a zero error code.

```

sstrg_save  adda.w  d2,a1           Adjust the buffer pointer
           move.w  d2,d1           And set the number of bytes sent

```

```

exit_ok    moveq    #0,d0                No errors
          rts                    And exit

```

Although we checked above for most of the input operations, there are still a couple that could be requested. Some 'nonsense' operations may have been requested for this device.

Filter these out and return 'bad parameter' errors for the nonsense ones or 'end of file' for the input ones.

```

not_save   cmpi.b    #fs_mdinf,d0        Read media information, EOF
          beq.s     error_ef
          cmpi.b    #fs_headr,d0        Read file header, EOF
          beq.s     error_ef
          cmpi.b    #fs_load,d0         Load a file, EOF
          beq.s     error_ef
          cmpi.b    #fs_check,d0        Silly codes such as CLS, PAPER etc
          bcs.s     error_bp            Silly ...
          cmpi.b    #fs_posre,d0
          bhi.s     error_bp            Silly ...

```

Now that we are here, we must have a valid operation code. None of the remaining operations require any processing, so simply return back to the caller with no errors.

```

rest_ok    bra.s     exit_ok            All the rest, just return ok
          END

```

And that is all there is to it. You now have a new QDOS device to install on your QL, QXL etc and use it.

You might be wondering why I wrote this device as I already use Lightning? Well, I can let this device be supplied with my commercial programs but I cannot distribute any of Digital Precisions software as that would be a breach of copyright. Now you can distribute this software for no charge and no royalties are due.

It may not be the most elegant code in the world, but it has worked (perfectly) for the last 5 years on my machine and on a lot more when WinBack is being run. Use it and enjoy it.

THE BLACK HOLE - UTILISATION

In order to use the black hole device, you must first assemble the above source code, then LRESPR it into your QL. If you don't have Toolkit 2, then try DJToolkit's RESERVE_HEAP command or failing that, RESPR, LBYTES and CALL on a normal QL. The code length is about 170 bytes long.

Once installed, you can simply open a channel to it and start printing things to it. The following example shows how easy it can be :

```

OPEN #3,BLACK_HOLE
PRINT #3, 'BYE BYE BYE ...'
CLOSE #3

```

The text 'BYE BYE BYE ...' will simply vanish and will never be seen again. You can also LIST a SuperBasic program to the channel or even copy files to it.

The black hole is a useful tool for checking that all the files on a floppy disc can be read, simply type :

```

SPL_USE black_hole
WCOPY_ flpl_

```

then press ENTER and all files will be copied to the device. You must do the SPL_USE first or WCOPY will get confused about where to put the files.

In your programs, there is no need to have a test for a printer channel anymore. If the user does not wish to use a printer, simply open the channel to the printer as normal, but use the black_hole as the printer name. The following, non error checked, example shows the guts of how to do it.

```

DEF PROCEDURE initialise
:
    PRINT 'Type a printer name or filename or'
    INPUT 'press ENTER only for none '; p$
:
    IF p$ = '' then
        printer$ = 'Black_Hole'
    ELSE
        printer$ = p$
    END IF
:
    OPEN #3, printer$
END DEF

DEF PROC lprint(t$)
:
    PRINT #3, t$
END DEF

```

And so on. This reduces the amount of code generated (slightly) when the program is compiled and it also removes the need to make the test for a printer every time that you want to print something.

In the error trapping for the lprint procedure, you could trap[any 'drive full' errors and in this case, advise the user that any further printing will be lost, close the current printer channel then re-open it with the black hole as the device. This is exactly how WinBack handles this problem.

Disc errors or 'not found' errors could also be redirected to this device.

The black hole can be used from assembler, C, Pascal or any other language that allows you to open channels to a device. Please feel free to use it in your own programs as you see fit. Don't forget the small print above though. ■

Q-DRAUGHTS

Bangor, Wales - Dilwyn Jones

This program plays the game of draughts, also known as Checkers in some countries. The computer is the 'x' characters and always goes first. You are the 'o' characters, moving up the board. The object is to take all of your opponent's pieces, by jumping over them diagonally to a vacant square. Pieces are crowned when they reach the other end of the board, this gives them the ability to move backwards. Crowned pieces are represented by upper case letters, with normal pieces being lower case.

To keep the listing fairly short, the error trapping is pretty scant. The computer does not play a particularly strong game, as the position and move searches are not deep enough. But it allows multiple jumps (entered one at a time), crowning and spots who has won, which is more than can be said about some short draughts program listings.

Moves are entered as two character co-ordinate pairs, with the horizontal being represented by a letter from A to H (upper or lower case) and a

number from 0 to 7 for the vertical square, e.g. A0 for the bottom left corner. Press ENTER after the source square has been entered, type in the destination square and press ENTER. If you can make a multiple jump, enter the first as a single jump, then the program will ask for the '+TO' squares for subsequent jumps.

Although the program doesn't play a strong game as it stands, you may like to look through the listing to find out how it works and attempt to improve on it. Here are some hints.

Add an outer loop which allows multiple games to be played (currently, the program stops once one person has won).

Add an option to allow you, the player, to have first move. This would need a variable to be set at the beginning of the program to allow the very first computer move to be skipped, then set to a different value from then on to allow the computer to move.

At the moment, a computer move becomes predictable after a while, e.g. the first move is always the same. You may like to add a random element to the moves so that every once in a while, a random move will appear to be a totally brilliant move.

Advanced users may like to adapt or copy the computer move routines to allow the computer to suggest a move for you.

board() is the array which holds the board. board(0,0) is the bottom left corner of the board on the screen. The values held are as follows:

- 2 is a crowned QL piece
- 1 is a normal QL piece
- 0 is a vacant square
- 1 is a normal player piece
- 2 is a crowned player piece

The procedures SCAN_AROUND and EVALUATE_POSITION rate the various moves possible and assign 'scores' based on the program's guess at the worth of a particular move. The variable 'best_move' keeps tab of the highest scored move analysed thus far, and the from and to square co-ordinates are held in the array 'bestmove()', the lower two elements holding the from square co-ordinates and the higher two holding the to square co-ordinates.

The code within the "enter_from" repeat loop is designed to handle the player move inputs. You can add more code here to improve the error trapping. The current error trapping only ensures moves are made from and to black squares. It does not check the letters and numbers entered as co-ordinates for example.

CLEAR_SQUARE is a procedure which clears a single square on the display.

SHOW_PIECE_AT prints the relevant piece on a given square on the board.

SOMEONE_WON is a short function which counts how many pieces the QL and the player have each. If either is 0, the other has one.

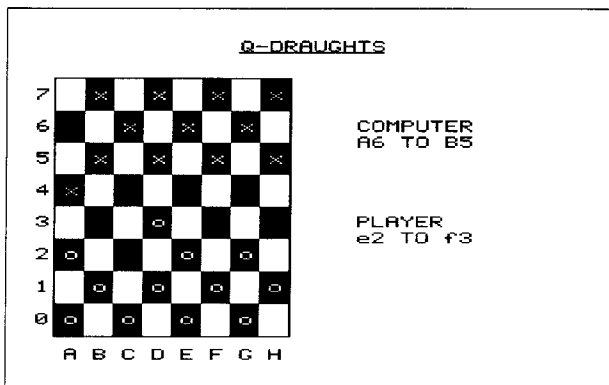

```

100 REMark Q-Draughts
110 WINDOW #0,512,256,0,0 : PAPER #0,7 : INK #0,0 :
CLS #0 : CSIZE #0,2,0
120 DRAW_BOARD
130 :
140 DIM bestmove(3) : REMark 0=best score,1-2=from
square,3-4=to square
150 best_move = -999 : REMark means no best move yet
160 DIM board(7,7) : REMark 0,0 is bottom left, i.e.
A0
170 RESTORE

```

```

180 FOR y = 7,6,5,2,1,0
190   FOR x = 0 TO 7 : READ board(x,y)
200 END FOR y
210 REMark computer pieces for top of screen
220 DATA 0,-1,0,-1,0,-1,0,-1
230 DATA -1,0,-1,0,-1,0,-1,0
240 DATA 0,-1,0,-1,0,-1,0,-1
250 DATA 1,0,1,0,1,0,1,0
260 DATA 0,1,0,1,0,1,0,1
270 DATA 1,0,1,0,1,0,1,0
280 :
290 REPEAT this_game
300   best_move = -999 : REMark no best move yet
310   REPEAT QL_move
320     eval = 0
330     FOR x = 0 TO 7
340       FOR y = 0 TO 7
350         IF board(x,y) < 0 THEN
360           REMark this square contains a QL piece
370           FOR across = -1,1
380             FOR up = -1 TO (-1+(2*(board(x,y) =
-2))) STEP 2
390               SCAN_AROUND
400               END FOR up
410               END FOR across
420             END IF
430           END FOR y
440         END FOR x
450         REMark if QL cannot move...
460         IF best_move = -999 THEN EXIT QL_move
470         REMark implement best move
480         board(bestmove(2),bestmove(3)) = board(
bestmove(0),bestmove(1))
490         board(bestmove(0),bestmove(1)) = 0 : REMark
blank FROM square
500         AT #0,8,24 : CLS #0,4
510         PRINT #0,CHR$(65+bestmove(0));bestmove(1);'
TO ';
520         PRINT #0,CHR$(65+bestmove(2));bestmove(3);
530         CLEAR_SQUARE bestmove(0),bestmove(1)
540         SHOW_PIECE_AT bestmove(2),bestmove(3)
550         IF bestmove(3) = 0 AND board(bestmove(2),
bestmove(3)) = -1 THEN
560           REMark crown QL piece which has moved to
row A
570           board(bestmove(2),bestmove(3)) = -2 :
REMark QL crown value
580           SHOW_PIECE_AT bestmove(2),bestmove(3)
590         END IF
600         REMark source and destination squares set,
but not in-between
610         REMark (jumped) squares at this point.
620         REMark bale out if not a jump (move finished)
630         IF ABS(bestmove(0)-bestmove(2)) <> 2 THEN
EXIT QL_move
640         REPEAT jumps
650           REMark jumped a player piece, this routine
handles any extra
660           REMark jumps, but first, remove jumped
player piece
670           board((bestmove(0)+bestmove(2))/2,
(bestmove(1)+bestmove(3))/2)=0
680           CLEAR_SQUARE (bestmove(0)+bestmove(2))/2,
(bestmove(1)+bestmove(3))/2
690           x = bestmove(2) : y = bestmove(3) : REMark
new position
700           best_move = -999 : REMark start looking for
next 'best move'
710           FOR up=-2 TO (-2+(4*(board(x,y)=2))) STEP 2
720             FOR across = -2,2
730               newx = x + across : newy = y + up :
REMark jump dest. square
740               IF newx >= 0 AND newx <= 7 AND newy >=
0 AND newy <= 7 THEN
750                 IF board(newx,newy)=0 AND board(x+
(across/2),y+(up/2))>0 THEN

```



```

760          REMark halfway square contains a
player piece and
770          REMark destination square is
vacant, so evaluate as a
780          REMark possible move
790          EVALUATE_POSITION
800          END IF
810          END IF
820          END FOR across
830          END FOR up
840          IF best_move = -999 THEN EXIT jumps
850          REMark a move of some sort (i.e. another
jump) decided upon
860          AT #0,8,24 : CLS #0,4 : PRINT #0,
CHR$(65+x); y; 'TO ';
870          PRINT #0, CHR$(65+bestmove(2)); bestmove(3);
880          CLEAR_SQUARE x,y
890          board(bestmove(2),bestmove(3))= board(
bestmove(0),bestmove(1))
900          board(bestmove(0),bestmove(1)) = 0 : REMark
clear from square
910          SHOW_PIECE_AT bestmove(2),bestmove(3)
920          IF board(bestmove(2),bestmove(3)) = -1 AND
bestmove(3)=0 THEN
930          REMark crown QL piece upon move to bottom
of board
940          board(bestmove(2),bestmove(3)) = -2
950          SHOW_PIECE_AT bestmove(2),bestmove(3)
960          END IF
970          END REPEAT jumps
980          EXIT QL_move
990          END REPEAT QL_move
1000         winner = SOMEONE_WON : IF winner <> 0 THEN
EXIT this_game
1010         :
1020         REMark player move
1030         REPEAT enter_from
1040         AT #0,14,24 : CLS #0,4 : INPUT #0,mve$
1050         from_x = CODE(mve$) - 65 : from_y = CODE(
mve$(2)) - 48
1060         IF from_x > 31 THEN from_x =from_x - 32 :
REMark lower case
1070         REMark can only move from black square
1080         IF (from_x MOD 2) <> (from_y MOD 2) THEN
BEEP 5000,50 : NEXT enter_from
1090         jumped% = 0 : REMark used for counting jump
moves
1100         REPEAT enter_to
1110         AT #0,14,26
1120         IF jumped% = 0 THEN PRINT #0, ' ' ; ELSE
PRINT #0, '+';
1130         INPUT #0, 'TO '; mve$
1140         to_x = CODE(mve$) - 65 : to_y = CODE(mve$
(2)) - 48
1150         IF to_x > 31 THEN to_x = to_x - 32
1160         REMark can only move to black square
1170         IF (to_x MOD 2) <> (to_y MOD 2) THEN BEEP
5000,50 : NEXT enter_from
1180         board(to_x,to_y) = board(from_x,from_y)
1190         REMark does it need to be crowned?
1200         IF to_y = 7 AND board(to_x,to_y) = 1 THEN
board(to_x,to_y) = 2
1210         board(from_x,from_y) = 0
1220         CLEAR_SQUARE from_x,from_y : SHOW_PIECE_AT
to_x,to_y
1230         IF ABS(to_x-from_x) = 1 THEN EXIT
enter_from
1240         REMark jump, so remove QL piece
1250         jumped% = 1 : REMark for different prompt
next time
1260         board((from_x+to_x)/2,(from_y+to_y)/2) = 0
1270         CLEAR_SQUARE (from_x+to_x)/2,(from_y+
to_y)/2
1280         REMark after a jump, there may be an
optional second jump
1290         from_x = to_x : from_y = to_y

```

```

1300         REMark scan around this square...
1310         REMark look forward first
1320         another% = 0 : REMark can player jump
again?
1330         FOR acr = -2,2
1340         FOR dn = -2,2
1350         IF dn = 2 OR (dn = -2 AND board(from_x
,from_y) = 2) THEN
1360         tx = from_x + acr : ty = from_y + dn
1370         IF tx >= 0 AND tx <= 7 AND ty >= 0
AND ty <= 7 THEN
1380         REMark at least it's on the board
1390         IF board(tx,ty) = 0 AND board((
from_x+tx)/2,(from_y+ty)/2) < 0 THEN another% = 1 :
EXIT acr
1400         END IF
1410         END IF
1420         END FOR dn
1430         END FOR acr
1440         IF another% = 0 THEN EXIT enter_from
1450         END REPEAT enter_to
1460         END REPEAT enter_from
1470         winner = SOMEONE_WON : IF winner <> 0 THEN
EXIT this_game
1480         END REPEAT this_game
1490         IF winner = -1 THEN
1500         AT #0,20,24 : PRINT #0, 'QL WINS!'
1510         ELSE
1520         AT #0,20,24 : PRINT #0, 'PLAYER WINS!'
1530         END IF
1540         STOP
1550         :
1560         DEFine PROCEDURE DRAW_BOARD
1570         LOCAL x,y
1580         AT #0,2,16 : UNDER #0,1 : PRINT #0, 'Q-DRAU
GHTS' : UNDER #0,0
1590         BLOCK #0,196,162,40,44,0
1600         FOR y = 0 TO 7
1610         FOR x = (y MOD 2) TO (y MOD 2)+6 STEP 2
1620         BLOCK #0,24,20,42+24*x,45+20*y,7
1630         END FOR x
1640         END FOR y
1650         FOR x = 0 TO 7 : CURSOR #0,48+24*x,212 : PRINT
#0, CHR$(65+x);
1660         FOR y = 0 TO 7 : CURSOR #0,24,50+20*y : PRINT
#0, CHR$(55-y);
1670         OVER #0,1 : INK #0,7
1680         AT #0,5,4 : PRINT #0, ' x x x x'
1690         AT #0,7,4 : PRINT #0, 'x x x x'
1700         AT #0,9,4 : PRINT #0, ' x x x x'
1710         AT #0,15,4 : PRINT #0, 'o o o o'
1720         AT #0,17,4 : PRINT #0, ' o o o o'
1730         AT #0,19,4 : PRINT #0, 'o o o o'
1740         INK #0,0 : OVER #0,0 : AT #0,7,24 : PRINT
#0, 'COMPUTER'
1750         AT #0,13,24 : PRINT #0, 'PLAYER'
1760         END DEFine DRAW_BOARD
1770         :
1780         DEFine PROCEDURE CLEAR_SQUARE(xx,yy)
1790         OVER #0,0 : BLOCK
#0,24,20,42+24*xx,45+(20*(7-yy)),0
1800         END DEFine CLEAR_SQUARE
1810         :
1820         DEFine PROCEDURE SHOW_PIECE_AT (xx,yy)
1830         AT #0,19-yy-yy,4+xx+xx : INK #0,7 : PAPER #0,0
1840         pc = board(xx,yy) : REMark piece at this point
1850         SELECT ON pc
1860         =-2 : PRINT #0, 'X'; : REMark QL crowned
1870         =-1 : PRINT #0, 'x'; : REMark QL uncrowned
1880         =1 : PRINT #0, 'o'; : REMark player
uncrowned
1890         =2 : PRINT #0, 'O'; : REMark player crowned
1900         END SELECT
1910         INK #0,0 : PAPER #0,7
1920         END DEFine SHOW_PIECE_AT
1930         :

```

```

1940 DEFine PROCedure SCAN_AROUND
1950 REMark was the subroutine at 650
1960 REMark scan around the square
1970 eval = 0 : newx = x + across : newy = y + up
1980 IF newx < 0 OR newx > 7 OR newy < 0 OR newy > 7 THEN RETURN
1990 REMark is the square already occupied by a QL
piece
2000 IF board(newx,newy) < 0 THEN RETURN
2010 REMark is the square vacant?
2020 IF board(newx,newy) = 0 THEN EVALUATE_POSITION
: RETURN
2030 REMark we now know that the square contains a
player piece - can
2040 REMark the QL jump it? Look one square further
2050 newx = newx + across : newy = newy + up
2060 REMark it would be embarrassing if this square
was off the board
2070 IF newx < 0 OR newx > 7 OR newy < 0 OR newy > 7 THEN RETURN
2080 IF board(newx,newy) = 0 THEN EVALUATE_POSITION
2090 END DEFine SCAN_AROUND
2100 :
2110 DEFine PROCedure EVALUATE_POSITION
2120 REMark move from x,y to newx,newy
2130 IF newy = 0 AND board(x,y) = -1 : eval = eval
+ 2 : REMark crown
2140 IF ABS(y-newy) = 2 : eval = eval + 5 : REMark
jump
2150 IF y = 7 : eval = eval + 2 : REMark move from
top of board
2160 FOR offset = -1,1
2170 IF newx+offset>=0 AND newx+offset<=7 AND
newy-1>=0 THEN
2180 IF board(newx+offset,newy-1) < 0 THEN
2190 eval = eval + 1 : REMark
2200 ELSE
2210 IF newx-offset>=0 AND newx-offset<=7 AND
newy+1<=7 THEN
2220 IF board(newx+offset,newy+1) > 0 THEN
2230 IF board(newx-offset,newy+1)=0 OR
(newx-offset=x AND newy+1=y) THEN
2240 eval = eval - 2
2250 END IF
2260 END IF
2270 END IF
2280 END IF
2290 END IF
2300 END FOR offset
2310 IF eval > best_move THEN
2320 best_move = eval
2330 bestmove(0) = x : bestmove(1) = y
2340 bestmove(2) = newx : bestmove(3) = newy
2350 END IF
2360 eval = 0 : REMark reset for future use
2370 END DEFine EVALUATE_POSITION
2380 :
2390 DEFine FuNction SOMEONE_WON
2400 player = 0 : ql = 0 : REMark pieces count
2410 FOR y = 0 TO 7
2420 FOR x = 0 TO 7
2430 piece = board(x,y)
2440 SElect ON piece
2450 =-1,-2 : ql = ql + ABS(piece)
2460 =1,2 : player = player + piece
2470 END SElect
2480 END FOR x
2490 END FOR y
2500 IF player = 0 THEN RETURN -1 : REMark QL won
2510 IF ql = 0 THEN RETURN 1 : REMark player won
2520 RETURN 0
2530 END DEFine SOMEONE_WON

```

continued from page 14

The function can be called by:

```
PRINT Reverse$("yadoTLQ")
```

Reverse\$ must have the \$ on the end as does its formal parameter x\$ because they both are of the type string. The local variable Length% (of type integer) has been introduced simply to reduce typing and increase readability since the expression LEN(x\$) would occur 3 times in the function definition. LEN is a built in function returning the length of the given string. Reading the function definition through it says that if the length of the string is less than or equal to 1 then return the given string, otherwise return the last character followed by the reverse of the remaining part.

Each time Reverse\$ calls itself another x\$ (and Length%) is created so there is no interference between the different instances of the function Reverse\$.

While recursive procedures/functions are academically interesting they can use up a lot of stack space since they repeatedly call themselves and can be regarded as using the computer's resources inefficiently but if they make a program easier to understand and the program runs fast enough anyway then why not use them?

Going back to part 1 of this series you can see that all programs can be written using just 3 procedures:

```

10 Initialise
20 MainBody
30 FinishOff

```

The procedures need to be defined, of course, and this is where different programs differ. None of these procedures is likely to call itself so they are not recursive. Writing a program this way is known as "top down" which means you just write procedure names for parts of the program and then fill in the details (write the procedures) later. This is definitely a good way to tackle programs. ■

**Please do
not forget to
send us
YOUR article!**

The QL-Show Agenda

The following list should give you an idea what is going on in the QL scene. We list big, important QL shows as well as local subgroup meetings. Try to come to the main shows nearby you anyway, and if you happen to be near a subgroup meeting why not see what is going on there too? QL show organisers, please let us know about dates as soon as possible. Subgroup organisers, if you find your regular meeting dates not listed here then please tell us! Some of the meetings are yet to be fully confirmed, more details in the next issue:

- Sept. 7 Eindhoven, The Netherlands.** We plan to make it a big show, so please come. All important dealers will be present, so it should be an interesting meeting for all of us. If you've never been to an Eindhoven show, here's how to get there:
Come to Eindhoven on the motorway which comes from Venlo and goes to Antwerp (or vv.). Leave it at "Knoopunkt Leenderheide" (there's a large roundabout under the motorway) and head to the "Centrum". At the next roundabout, turn left and stay on this road until you reach the first traffic lights. Turn left here again, you should be on the "Roostenlaan" now. There are already small signs pointing to "St. Joris College" (the venue) and "Animali" (the zoo, opposite to the College). For more details contact Sjef van de Moolengraaf +31 40-442309. The show will start at 10am and will end at 5pm, but make sure you're there before 3 or 4pm!
- Sept. 21 Edinburgh, Scotland.** Contact: John Sadler 01592-268727 The venue is Edinburgh Academy.
- Oct. 6 Byfleet, Surrey, England.** Quanta Workshop. Contact: Ken Bain 01932-347432. The venue is now confirmed as Byfleet Village Hall.
- Nov. 2 Eindhoven, The Netherlands.** This is planned to be a very big show, a truly international meeting. If you missed the September show then it is definitely the show to go to. But it may be worthwhile to visit it anyway. Details as above.
- Nov. 9 England. All Format Show - Stuart!!**
- Nov. 17 Portishead (near Bristol, England)** (exact venue to be confirmed). Quanta Workshop. Contact: Mike Ashford 01934-415416

What's coming next?

Ah, this is really a good question! First of all, it mainly depends on YOU! Please send your articles, reviews, problems, tips ... whatever you think might interest other people who use the QL, QDOS or SMSQ and related topics (i.e. linking a QL to a PSION Series 3, to a Z88 ...).

The next issue will probably contain:

- Part 2 of the QL Service List.
- More articles which should have gone into IQLR but did not fit into the current issue.
- More hardware news.
- Lots of software news from PROGS.
- Competition riddle (for experts & beginners!).
- Review of QMenu.
- Programmer's explanation of Config Level 2 (it is so handy).
- Viruses and the QL
- More articles which were promised for the current issue - not all of the promised articles for issue 2 are actually in issue 2 - if you look at the contents you know why: there was absolutely no space left and we thought it would be more important to print articles which were left over from IQLR to make sure they are not too out of date - sorry, but you have to wait for issue 3 to read them.

Above are just a few of the very many reasons to subscribe for **QL Today** - why not do it now if you haven't already done it?